

# Measuring LTE Modulation Performance in a Distributed Antenna System (DAS) Environment

Viavi Solutions recently participated in the preparation for one of the largest sporting events in North America using its JD745A Base Station Analyzer. In conjunction with a major wireless service provider, a team of Viavi system engineers worked with operator engineers at a huge, multi-purpose stadium to ensure 4G LTE coverage at the event.



The existing 4G LTE network needed to be ready to handle capacity constraints imposed by the tens of thousands of additional subscribers on the network during the week-long event.

Engineers tested the DAS in the catwalk/rafters of the stadium roof, and several errors were immediately apparent. The JD745A quickly pinpointed LTE modulation quality issues which affected service. Previously, there had been no way to verify the quality of the LTE signal; the operator relied on its eNodeB vendors to verify that radio-frequency signals were working properly. The Viavi JD745A, a single, portable tool with advanced capabilities and one-button measurements identified the faulty external equipment and service levels were promptly restored.

A JD745A is the best tool to determine that signal quality originating from a base transceiver station (BTS) or eNodeB is maintained through cabling, installation, and ongoing maintenance. Testing signal quality and power levels ensures optimal data throughput and the voice capacity of a network by not degrading signals as they are being distributed.



JD745A Wireless Base Station Analyzer

## Modulation Formats

Signals transmitted over the air transport data modulated over a carrier. There are three variables that can be changed to modulate a signal: amplitude, frequency, and phase. In cellular networks, adjusting communication between cell sites and user equipment is typically done by changing amplitude and phase simultaneously.

Modulation analysis is performed using polar diagrams where the modulated signal is indicated using multiple symbols with two characteristics: a vector magnitude representing the signal's amplitude and a vector angle representing the signal's phase. An arrangement of multiple positions allows data communication. For example, the basic communication of a single bit (0 and 1) requires two symbols typically with the same amplitude but different phase: binary phase-shift keying (BPSK).

Higher modulation schemes transmit a series of symbols each with different amplitude and phase, allowing the communication of multiple bits at the same time, such as 64 quadrature amplitude modulation (QAM) that can transmit 64 symbols at different positions, each transmitting 6 bits.

The JD745A simultaneously shows every modulation format for LTE by individual downlink channel. This means an engineer can immediately gauge the importance of an error vector magnitude (EVM) measurement relative to the format. Importantly, the unit also clearly specifies which control or data channel is being analyzed.

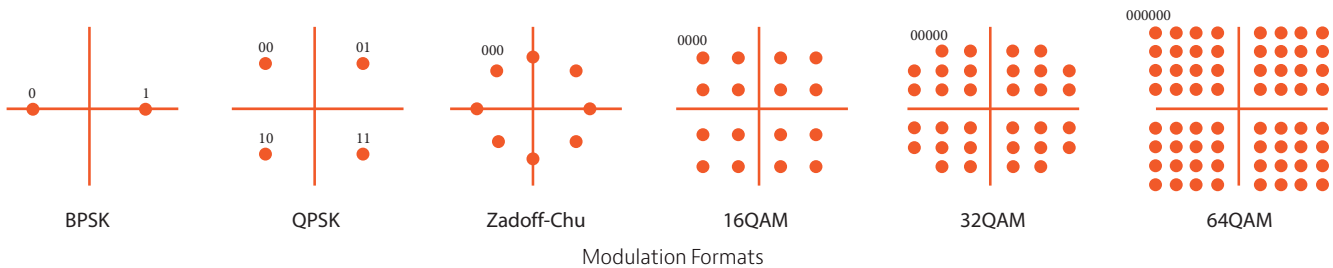

## Error Vector Magnitude (EVM)

EVM measurements can provide a great deal of insight into LTE modulation performance. EVM is expressed as the difference between the vector of an ideal symbol and the symbol under test. It is the percentage of error that indicates how far the symbol is transmitted from its ideal position. The higher the modulation, the higher the number of symbols, which results in a smaller margin of error.

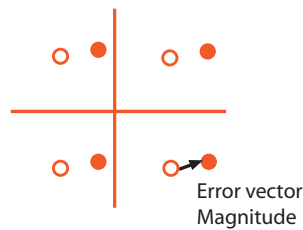

With proper use, EVM and related measurements can pinpoint exactly the types of degradations present in a signal and can even help identify their sources.

## Measuring EVM in DAS Environments

The JD745A performs EVM testing on LTE data and control channels such as reference signals. In this application example, the unit revealed modulation degradation at the antenna point of the DAS, indicating performance issues on that particular branch.

In addition, the JD745A can measure from each antenna on a MIMO configuration, identifying installation errors on cabling. The timely detection of these kinds of problems can prevent significant troubleshooting complications such as misidentification or mislabeling of network elements.

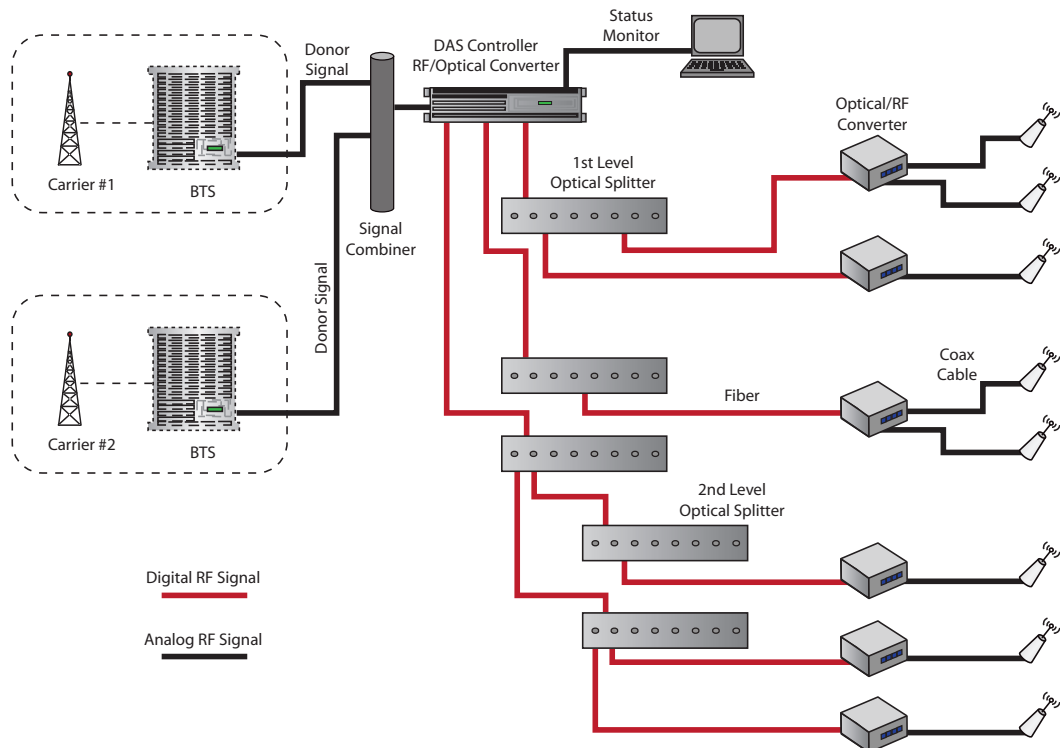

Distributed Antenna System (Hermes Wireless Solutions)

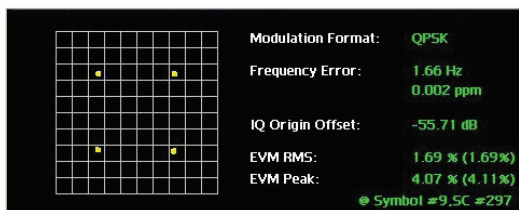

Reference Signal EVM at eNodeB

Low EVM RMS indicates a properly modulated signal.

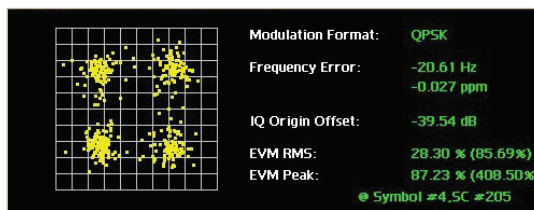

Reference Signal EVM at DAS

An unacceptably high EVM indicates a poorly modulated signal.

## Viavi Base Station Analyzers

The Viavi JD745A and JD7105B analyzers are the optimal test tools for installing and maintaining cell sites. They contain all the features and capabilities needed to successfully and comprehensively field test all wireless technologies, from 2G to 4G. The analyzers include one-button standards-based measurements for wireless signals and they offer the full scope of BTS conformance tests. Their combined functionality includes spectrum analysis, cable and antenna analysis, power metering, interference analysis, channel scanning, E1/T1 analysis, and signal analysis.

Contact your Viavi sales representative to learn more today, or visit us at [www.viavisolutions.com/lte](http://www.viavisolutions.com/lte).



Contact Us **+1 844 GO VIAVI**  
(+1 844 468 4284)

To reach the Viavi office nearest you,  
visit [viavisolutions.com/contacts](http://viavisolutions.com/contacts).

© 2015 Viavi Solutions Inc.  
Product specifications and descriptions in this  
document are subject to change without notice.  
Itedas-an-nsd-tm-ae  
30173135 900 0312