



OSPREY
GPS Simulator
Operation Manual



OSPREY
GPS Simulator
Operation Manual
22190377 **Rev. 002**



VIAVI Solutions
1-844-GO-VIAVI
www.viavisolutions.com

This page intentionally left blank.

Notice

Every effort was made to ensure that the information in this manual was accurate at the time of release. However, information is subject to change without notice, and VIAVI reserves the right to provide an addendum to this manual with information not available at the time that this manual was created.

Copyright/Trademarks

© Copyright 2026 VIAVI Solutions, Inc. All rights reserved. No part of this guide may be reproduced or transmitted, electronically or otherwise, without written permission of the publisher. VIAVI Solutions and the VIAVI logo are trademarks of VIAVI Solutions Inc. (“VIAVI”).

All other trademarks and registered trademarks are the property of their respective owners.

Patent Information

Patented as described at www.viavisolutions.com/patents

Copyright Release

Reproduction and distribution of this guide is authorized for US Government purposes only.

Terms and conditions

Specifications, terms, and conditions are subject to change without notice. The provision of hardware, services, and/or software are subject to VIAVI’s standard terms and conditions, available at www.viavisolutions.com/en/terms-and-conditions.

Declaration of Conformity

VIAVI recommends keeping a copy of the Declaration of Conformity that shipped with the unit at all times.

Warranty Information

Warranty information for this product is available on the VIAVI website at <https://www.viavisolutions.com/en-us/warranty-information>.

Federal Communications Commission (FCC)

This device complies with part 15 of the FCC Rules. Operation is subject to the following two conditions:

1. This device may not cause harmful interference.
2. This device must accept any interference received, including interference that may cause undesired operation.

This equipment was tested and found to comply with the limits for a Class A digital device, pursuant to Part 15 of the FCC Rules. These limits are designed to provide reasonable protection against harmful interference when the equipment is operated in a commercial environment. This equipment generates, uses, and can radiate radio frequency energy and, if not installed and used in accordance with the instruction manual, may cause harmful interference to radio communications. Operation of this equipment in a residential area is likely to cause harmful interference, in which case you will be required to correct the interference at your own expense.

The authority to operate this equipment is conditioned by the requirements that no modifications be made to the equipment unless the changes or modifications are expressly approved by VIAVI.

This product complies with 47 CFR Part 15 through use of a modular component authorized under a grant of certification:

- FCC ID: WUW-NINAB30



CAUTION

RF Radiation Exposure

- This equipment complies with the FCC RF radiation exposure limits set forth for an uncontrolled environment
- To comply with FCC RF exposure compliance requirements, a separation distance of at least 10 mm must be maintained between the antenna of this device and all persons
- This transmitter must not be co-located or operating in conjunction with any other antenna or transmitter

Innovation, Science and Economic Development Canada

This digital apparatus complies with CAN ICES-003 (A).

Cet appareil numérique est conforme à la norme CAN ICES-003 (A).

This device contains license-exempt transmitter(s)/receiver(s) that comply with Innovation, Science and Economic Development Canada's license-exempt RSS(s). Operation is subject to the following two conditions:

1. This device may not cause interference.
2. This device must accept any interference, including interference that may cause undesired operation of the device.

Cet appareil contient des émetteurs/récepteurs exempts de licence conformes aux normes CNR d'Innovation, Sciences et Développement économique Canada. Son utilisation est soumise aux deux conditions suivantes:

1. Cet appareil ne doit pas provoquer d'interférences.
2. Cet appareil doit accepter toute interférence, y compris celles qui peuvent entraîner un fonctionnement indésirable de l'appareil.

This product complies with relevant ISED Canada Radio Standard Specifications (RSS) through use of the following modular component authorized under a grant of certification:

- IC: 9613A-NINAB30

Ce produit est conforme aux spécifications des normes radio (RSS) pertinentes d'ISDE Canada grâce à l'utilisation du composant modulaire suivant, autorisé en vertu d'une certification:

- IC: 9613A-NINAB30

Continued on next page.



CAUTION

RF Radiation Exposure

- This equipment complies with ISED Canada radiation exposure limits set forth for an uncontrolled environment
- To comply with ISED Canada RF exposure compliance requirements, a separation distance of at least 15 mm must be maintained between the antenna of this device and all persons
- To comply with Canadian RF exposure requirements, this device and its antenna must not be collocated or operated in conjunction with any other antenna or transmitter

Mise en Garde

Exposition aux rayonnements RF

- Cet équipement est conforme aux limites d'exposition aux rayonnements d'ISDE Canada établies pour un environnement non contrôlé
- Pour se conformer aux exigences de conformité en matière d'exposition aux RF d'ISDE Canada, une distance de séparation d'au moins 15 mm doit être maintenue entre l'antenne de cet appareil et toutes les personnes
- Pour se conformer aux exigences canadiennes en matière d'exposition aux RF, cet appareil et son antenne ne doivent pas être colocalisés ou utilisés en conjonction avec une autre antenne ou un autre émetteur

EU WEEE and Battery Directives

This product, and the batteries used to power the product, should not be disposed of as unsorted municipal waste and should be collected separately and disposed of according to your national regulations.

VIAVI has established a take-back processes in compliance with the EU Waste Electrical and Electronic Equipment (WEEE) Directive, 2012/19/EU, and the EU Battery Directive, 2006/66/EC.

Instructions for returning waste equipment and batteries to VIAVI can be found in the WEEE section of [VIAVI's Standards and Policies web page](#).

If you have questions concerning disposal of your equipment or batteries, contact the VIAVI WEEE Program Management team at WEEE.EMEA@VIAVISolutions.com.

EU REACH

Article 33 of EU REACH regulation (EC) No 1907/2006 requires article suppliers to provide information if a listed Substances of Very High Concern (SVHC) is present in an article above a certain threshold.

For information on the presence of REACH SVHCs in VIAVI products, see the Hazardous Substance Control section of [VIAVI's Standards and Policies web page](#).

EU CE Marking Directives (LV, EMC, RoHS, RE)

This product conforms with all applicable CE marking directives. Please see EU Declaration of Conformity for details.

EMC Directive Compliance

This product was tested and conforms to the EMC Directive, 2014/30/EU for electromagnetic compatibility.

UK Declaration of Conformity

This product conforms with all applicable UKCA marking directives. Please request UK Declaration of Conformity for further details.

China RoHS Materials Declaration

The China RoHS Materials Declaration is shipped with the product when required.

California Proposition 65

California Proposition 65, officially known as the Safe Drinking Water and Toxic Enforcement Act of 1986, was enacted in November 1986 with the aim of protecting individuals in the state of California and the state's drinking water and environment from excessive exposure to chemicals known to the state to cause cancer, birth defects or other reproductive harm.

For the VIAVI position statement on the use of Proposition 65 chemicals in VIAVI products, see the Hazardous Substance Control section of [VIAVI's Standards and Policies web page](#).

Korea Certification

<p>A급 기기 (업무용 방송통신기자재)</p> <p>Class A Equipment (Industrial Broadcasting & Communications Equipment).</p>	<p>이 기기는 업무용(A급) 전자파적합기기로서 판매자 또는 사용자는 이 점을 주의하시기 바라며, 가정외의 지역에서 사용하는 것을 목적으로 합니다.</p> <p>This equipment is Industrial (Class A) electromagnetic wave suitability equipment and seller or user should take notice of it, and this equipment is to be used in the places except for home.</p>
---	---

Ordering information

This manual is a product of the VIAVI Technical Publications Department, issued for use with the OSPREY GPS Simulator. The PDF format of this manual is available on the VIAVI product website.

Go to: <https://www.viavisolutions.com/en-us/resources/literature-library>

- Type OSPREY to find the manuals and information associated with the OSPREY GPS Simulator.

Contact Information

VIAVI Solutions

10200 West York Street

Wichita, KS 67215

1-800-835-2350

OR

Contact the Technical Assistance Center (TAC) for technical support or with any questions regarding this or other VIAVI products.

- Phone: 1-844-GO-VIAVI
- Email: Techsupport.Avcomm@viavisolutions.com

For the latest TAC information, go to:

<https://www.viavisolutions.com/support/technical-product-support>

Software Notifications

DFARS Statement

If software is for use in the performance of a U.S. Government prime contract or subcontract, software is delivered and licensed as “Commercial Computer Software” as defined in DFAR 252.227-7014 (Feb 2014), or as a “Commercial Item” as defined in FAR 2.101(a) or as “Restricted Computer Software” as defined in FAR 52.227-19 (Dec 2007) or any equivalent agency regulation or contract clause. Use, duplication or disclosure of Software is subject to VIAVI Solutions' standard commercial license terms, and non-DOD Departments and Agencies of the U.S. Government will receive no greater than Restricted Rights as defined in FAR 52.227-19(c)(1-2) (Dec 2007). U.S. Government users will receive no greater than Limited Rights as defined in FAR 52.227-14 (June 1987) or DFAR 252.227-7015 (b)(2) (November 1995), as applicable in any technical data.

Open Source Disclaimer - IMPORTANT READ CAREFULLY

The OSPREY GPS Simulator includes third party software licensed under the terms of separate open source software licenses. By using this software you agree to comply with the terms and conditions of the applicable open source software licenses. Software originated by VIAVI is not subject to third party licenses. Terms of the VIAVI Software License different from applicable third party licenses are offered by VIAVI alone.

This page intentionally left blank.









Safety and Compliance Information

Read and follow all warning notices and instructions marked on the product and included in user documentation.

Symbols and Markings

The following symbols and markings are found on the instrument and in product documentation:

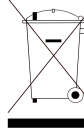
Table 1 Symbols and Markings

	This symbol indicates a note that includes important supplemental information or tips related to the main text.
	Attention Symbol This symbol represents a general hazard. It may be associated with either a DANGER, WARNING, CAUTION, or ALERT message. See Table 2 for more information.
	ESD Sensitive Indicates item is static sensitive. Item should only be handled by Qualified Service Personnel.
	Explosive Hazard This symbol represents a risk of explosion. It may be associated with either a DANGER, WARNING, CAUTION or ALERT message.
	Voltage Symbol This symbol represents hazardous voltages. It may be associated with either a DANGER, WARNING, CAUTION, or ALERT message. See Table 2 for more information.
	Toxic Symbol Indicates a toxic hazard. Item should only be handled by Qualified Service Personnel. Dispose of item in accordance with local regulations.
	WEEE Symbol This symbol, located on the equipment or the packaging indicates that the equipment must not be disposed of in a land-fill site or as municipal waste, and should be disposed of according to your national regulations.
	CE Compliant CE Label indicates item meets the requirements of the applicable European Directives.
	Fuse Symbol Indicates a fuse location (AC or DC).

Safety Definitions

This manual uses the following terms to indicate conditions or activities which are potential safety hazards:

Table 2 Safety Definitions

Term	Definition
WARNING	Identifies conditions or activities that, if ignored, can result in personal injury or death.
Avertissement	Identifiez les conditions ou les activités qui, si ignorées, peuvent entraîner des blessures personnelles voire mortelles.
CAUTION	Identifies conditions or activities that, if ignored, can result in equipment or property damage, e.g., Fire.
Mise en Garde	Identifiez les conditions ou les activités qui, si ignorées, peuvent entraîner des dommages à l'équipement ou aux biens, p. ex. un incendie.

Safety Hazards

Toxic Hazards



WARNING

Some of the components used in this device may include resins and other materials which give off toxic fumes if incinerated. Dispose of such items appropriately.

Avertissement

Certains des composants utilisés dans cet appareil peuvent comprendre des résines et d'autres matériaux qui produisent des émanations toxiques lorsqu'ils sont incinérés. Éliminez adéquatement de tels éléments.



WARNING

Lithium-Ion batteries are used in this equipment. Lithium is a toxic substance.

- Do not crush, incinerate or dispose of in normal waste.
- Do not short circuit or force discharge since this might cause the battery to vent, overheat or explode.

WEEE and Battery Statement

This product and the batteries used to power the product, should not be disposed of as unsorted municipal waste and should be collected separately and disposed of according to local regulations.

VIAVI has established a take-back processes in compliance with the EU Waste Electrical and Electronic Equipment (WEEE) Directive, 2012/19/EU, and the EU Battery Directive, 2006/66/EC.

Information and instructions for returning waste equipment and batteries to VIAVI can be found on the VIAV website in the WEEE section of VIAVI's Standards and Policies web page at: [VIAVI's Standards and Policies](#) web page.

Lithium-Ion



WARNING

Lithium-Ion batteries are used in this device. Lithium is a toxic substance, so the batteries should in no circumstances be crushed, incinerated or disposed of in normal waste.

- Do not attempt to recharge this type of battery.
- Do not short circuit or force discharge since this might cause the battery to vent, overheat or explode.



CAUTION

This device contains Lithium-Ion batteries and require special packaging and external labeling when shipping. Contact VIAVI for packaging and labeling instructions.

Mise en Garde

Cet appareil contient des batteries lithium-ion et peut nécessiter un emballage et un étiquetage spécifiques pendant le transport. Contactez VIAVI pour obtenir les instructions d'emballage et d'étiquetage.

Electrical Hazards

Grounding the Instrument

The instrument is provided with a protective grounding lead that conforms with IEC Safety Class I. The supply lead must always be connected to the power supply via a grounded contact in order to maintain the grounding protection. The instrument must be properly grounded to prevent damage to the device from electrostatic discharge (ESD).



WARNING

Improper grounding of equipment can result in electrical shock. To ensure proper grounding, this device should only be connected to a grounded AC Power Supply.

Avertissement

La mise à la terre inadéquate de l'équipement peut entraîner un choc électrique. Pour s'assurer d'une mise à la terre adéquate, cet appareil doit seulement être branché à une alimentation électrique CA mise à la terre.

Input Overload

Refer to product labeling and product specifications for maximum input ratings.



CAUTION

Do not overload input connectors. Refer to product specifications or the product data sheet for maximum input ratings.

Mise en Garde

Ne surchargez pas les connecteurs d'entrée. Reportez-vous aux spécifications du produit ou à la fiche technique du produit pour connaître les valeurs d'entrée maximales.

AC Power Adapter/Cord

Approved Part: 22176099, Power Adapter 5V USB.

The base unit with all applications installed can operate supplied by the 100 - 240VAC, 5.0V;2.1A / 10.5W Power Adapter that is shipped with the unit.



CAUTION

- Only use the AC Power Adapter/Cord supplied with the instrument.
- Do not use the AC Power Adapter/Cord outdoors or in a wet or damp location.
- Only connect the AC Power Adapter/Cord to the correct mains voltage indicated on the ratings label.
- Do not use the AC Power Adapter/Cord if it appears damaged or modified.

Mise en Garde

- Utilisez uniquement l'adaptateur secteur / le cordon d'alimentation fourni avec l'instrument.
- N'utilisez pas l'adaptateur secteur / le cordon d'alimentation à l'extérieur ou dans un endroit mouillé ou humide.
- Connectez uniquement l'adaptateur secteur / cordon d'alimentation à la tension secteur appropriée indiquée sur l'étiquette des caractéristiques nominales.
- N'utilisez pas l'adaptateur / cordon d'alimentation secteur s'il semble endommagé ou s'il a été modifié.



CAUTION

- Do not use the power cord if it is damaged or frayed. Replace damaged power cords with cable of the same ratings.
- Do not position the power cord in a manner that makes it difficult to disconnect from the main voltage.
- Do not allow anything to rest on the power cord.
- Do not locate the product where persons can walk on or trip over the power cord.

Mise en Garde

- N'utilisez pas le cordon d'alimentation s'il est endommagé ou effiloché. Remplacez les cordons d'alimentation endommagés par des câbles de même puissance.
- Ne placez pas le cordon d'alimentation de manière à rendre difficile la déconnexion de la tension secteur.
- Ne laissez rien reposer sur le cordon d'alimentation.
- Ne placez pas le produit à un endroit où des personnes pourraient marcher ou trébucher sur le cordon d'alimentation.

Battery Safety Information

There are two batteries included with the product, and are only to be used with VIAVI OSPREY GPS Simulator.

Battery Storage, Handling and Disposal



CAUTION

- To avoid risk of fire and burns, do not tamper with the batteries.
- Do not open, crush, or incinerate the batteries.
- Do not use or store the batteries in temperatures that exceed product specifications.
- Avoid shorting the batteries.
- Never use a battery that appears damaged or abused.
- Only charge the batteries with the charger that shipped with the OSPREY.

Mise en Garde

- Ne pas ouvrir, écraser ni incinérer la batteries.
- N'utilisez pas et ne stockez pas la batteries à des températures dépassant les spécifications du produit.
- Évitez de court-circuiter la batteries.
- N'utilisez jamais une batterie qui semble endommagée ou qui a subi des abus.
- Accusez seulement la batteries du chargeur qui a expédié avec le jeu d'essai.

Battery Replacement

Approved Part Number: 22189092, Rechargeable Lithium-Ion Battery



CAUTION

The two batteries supplied with the device shall only be replaced with a VIAVI approved replacement part.

Mise en Garde

Les deux batteries fournies avec l'appareil doivent être remplacées uniquement par une pièce de rechange approuvée par VIAVI.

Equipment Usage

This device is designed and tested to comply with the requirements of 'IEC/EN 61010-1, 3rd Edition Safety Requirements for Electrical Equipment for Measurement, Control and Laboratory Use' for Class I portable equipment and is for use in a pollution degree 2 environment.



WARNING

Operating this device in a manner not specified in accompanying documentation may impair the safety protection built into the device.

Avertissement

Utiliser cet appareil de manière non spécifiée dans la documentation d'accompagnement peut nuire au dispositif de protection de sécurité intégré dans l'appareil.



CAUTION

- Use of equipment: short-term
- Intended for indoor use only
- Not suitable for wet location
- Designed to meet MIL-PRF-28800 Class III requirements
 - Temperature
 - Humidity
 - Transit Drop
 - Altitude

Mise en Garde

- Utilisation du matériel : à court terme
- Conçu pour un usage intérieur uniquement
- Ne convient pas aux endroits humides
- Conçu pour répondre aux exigences de la norme MIL-PRF-28800 Classe III
 - Température
 - Humidité
 - Dépôt de transit
 - Altitude

Electrostatic Discharge (ESD)



CAUTION

Internal components are ESD sensitive and should only be installed, removed and/or serviced by Qualified Service Personnel.

Mise en Garde

Les composants internes sont sensibles au DES et ne doivent être installés, retirés ou entretenus que par du personnel de maintenance qualifié.

Case/Cover Removal

Do not operate this device with the case or covers removed. Opening or removing covers may expose you to dangerous high voltage points and other hazards.



CAUTION

This device does not contain user serviceable parts. Servicing should only be performed by Qualified Service Personnel.

Mise en Garde

Cet appareil ne contient pas de pièces pouvant être entretenues par l'utilisateur. L'entretien doit seulement être effectué par du personnel de service qualifié.



Table of Contents

	• Software Notifications	1-7
Chapter 1	OSPREY Overview	1-1
	1.1 General Information	1-2
	1.2 Principles of Operation	1-3
	1.3 Features and Capabilities	1-3
	1.4 Controls and Connectors	1-4
Chapter 2	Setup, Control, and Operation	2-1
	2.1 Upon Receipt	2-2
	2.2 First Time Use	2-4
	2.3 Verify Operation	2-6
	2.4 Control and Operation	2-7
	2.5 Screens	2-8
	2.6 UI Navigation, Control and Layout	2-11
	2.7 Input/Output Connectors	2-12
	2.8 Updating OSPREY Software	2-12
Chapter 3	System Settings Screens	3-1
	3.1 System Settings Screens	3-2
Chapter 4	Configuring System Settings	4-1
	4.1 Establishing Wireless Connection	4-2
	4.2 Remotely Operating the Device	4-2
Chapter 5	GPS Simulator Functions	5-1
	5.1 Almanac Download	5-2
	5.2 Create / Manage Static Waypoints	5-3
	5.3 Create / Manage Dynamic Routes	5-4

Chapter 6	Performing Simulations	6-1
	6.1 Performing Simulations from the Mobile Application	6-2
	6.2 Performing Simulations from the OSPREY GPS Simulator	6-4
Chapter 7	Care and Maintenance	7-1
	7.1 Storage Instructions	7-2
	7.2 Return Material Authorization (RMA)	7-2
	7.3 Shipping Instructions	7-2
	7.4 Operator Level Maintenance	7-3
	7.5 Case/Cover Removal	7-4
	7.6 Battery Recharge	7-5
	7.7 Battery Replacement Instructions	7-6
	7.8 Battery Replacement	7-7
Appendix A	OSPREY Specifications	A-1
	A.1 Specifications	A-2
Appendix B	Abbreviations	B-1
	Appendix B. Abbreviations	B-2



List of Tables

Table	Title	Page
Table 1-1	OSPREY Controls and Connectors	1-5
Table 2-1	OSPREY Standard Items per Configuration	2-3
Table 2-2	OSPREY Optional Accessories	2-3
Table 2-3	OSPREY GPS Simulator Screens	2-8
Table 2-4	OSPREY GPS Simulator Screens	2-9
Table 7-1	Battery and Adapter Cord Replacement Part Numbers	7-6
Table 7-2	Tool Requirements	7-6
Table 7-3	Battery Replacement Part Number	7-7
Table B-1	Appendix B Abbreviations	B-2

This page intentionally left blank.

List of Figures

Figure	Title	Page
Figure 1-1	OSPREY Single Coupler Configuration (Front / Back)	1-2
Figure 1-2	Mobile application	1-4
Figure 1-3	OSPREY Front Panel Display / Control	1-4
Figure 1-4	OSPREY Controls and Connectors	1-5
Figure 2-1	OSPREY Display showing Device ID	2-6
Figure 2-2	Mobile App connection screen	2-6
Figure 2-3	OSPREY Connected LED	2-7
Figure 2-4	OSPREY Mobile App Home and Connection screens	2-10
Figure 2-5	OSPREY Mobile App Almanac, Static and Dynamic screens	2-10
Figure 2-6	OSPREY Mobile App Remote Control and Settings screens	2-11
Figure 2-7	Front panel controls and buttons	2-11
Figure 2-8	OSPREY I/O Connectors	2-12
Figure 3-1	SettingsScreen	3-2
Figure 5-1	Selecting Download Almanac	5-2
Figure 5-2	Create/Manage Static Waypoints	5-3
Figure 5-3	Create/Manage Static Waypoints 2	5-3
Figure 5-4	Create / Manage Dynamic Routes	5-4
Figure 5-5	Create / Manage Dynamic Routes 2	5-5
Figure 6-1	Performing Simulations from the Mobile Application	6-2
Figure 6-2	Performing Simulations from the Mobile Application 2	6-3
Figure 6-3	Static Simulation	6-4
Figure 6-4	Dynamic Simulation	6-4
Figure 7-1	Base Cover Removal	7-8

This page intentionally left blank.



Preface

This section explains how to use this manual. Topics discussed include the following:

- Content Overview 2
 - Purpose and Scope 3
 - Product Nomenclature 3
 - Ordering information 3
 - Intended Audience 3
- Related Information 4
- Contact Information 4

Content Overview

This manual is composed of the following chapters:

Chapter 1: Overview

Provides an overview of the OSPREY GPS Simulator's features and capabilities.

Chapter 2: Setup, Control, and Operation

Provides instructions for setting up the OSPREY GPS Simulator and also provides an overview of the device's User Interface (UI).

Chapter 3: System Settings Screens

Provides a description of the OSPREY system functions and the controls and settings located on each screen.

Chapter 4: Configuring System Settings

Describes setup procedures and settings for the OSPREY GPS Simulator.

Chapter 5: GPS Simulator Functions

Provides an overview of the GPS Simulator Functions.

Chapter 6: Performing Simulations

Provides instructions for performing simulations.

Chapter 7: Care and Maintenance

Provides storage and shipping instructions as well as care and maintenance procedures for the OSPREY.

Appendix A: Specifications

OSPREY GPS Simulator Specifications.

Appendix B: Abbreviations

Abbreviations.

Purpose and Scope

The purpose of this Operations Manual is to help users successfully use the OSPREY features and capabilities. This Operations Manual includes task-based instructions that describe how to configure, use and troubleshoot the OSPREY GPS Simulator.

This Operations Manual also provides VIAVI contact information for VIAVI warranties, technical assistance, repair information, and contact information for VIAVI's Technical Assistance Center (TAC).

Product Nomenclature

The following terms may be used in this Operations Manual to refer to the OSPREY GPS Simulator.

- OSPREY
- GPS Simulator
- OSPREY GPS Simulator

Ordering information

This manual is a product of the VIAVI Technical Publications Department, issued for use with the OSPREY GPS Simulator. The PDF format of this manual is available on the VIAVI product website.

- The part number associated with this publication is 22190377
- Type OSPREY to find the manuals and information associated with the OSPREY GPS Simulator.

Go to: <https://www.viavisolutions.com/en-us/resources/literature-library>

Intended Audience

This Operations Manual is intended for personnel who are familiar with avionics test systems, associated equipment, and corresponding terminology.

This Operations Manual is intended for novice, intermediate, and experienced users who want to use the OSPREY GPS Simulator effectively and efficiently.

Related Information

This is the Operations Manual for the OSPREY GPS Simulator. This Operations Manual provides instructions for setting up the OSPREY GPS Simulator, instrument specifications, and contact information for VIAVI's Technical Assistance Center (TAC).

Read this manual carefully before setting up or operating the instrument.

Use this manual in conjunction with the following information:

- The OSPREY Quick Start Guide 22190483 which provides a basic overview of installation and use.

Contact Information

VIAVI Solutions

10200 West York Street

Wichita, KS 67215

1-800-835-2350

OR

Contact the Technical Assistance Center (TAC) for technical support or with any questions regarding this or other VIAVI products.

- Phone: 1-844-GO-VIAVI
- Email: Techsupport.Avcomm@viavisolutions.com

For the latest TAC information, go to:

<https://www.viavisolutions.com/support/technical-product-support>

OSPREY Overview

This chapter describes OSPREY GPS Simulator controls, connectors, functions, and capabilities. This chapter also provides a general description of the OSPREY.

Topics discussed in this chapter include the following:

- [General Information](#) 1-2
- [Principles of Operation](#) 1-3
- [Features and Capabilities](#) 1-3
- [Controls and Connectors](#) 1-4

1.1 General Information

The OSPREY GPS Simulator is a self-contained GPS Simulator capable of providing GPS L1 simulation of static waypoints and dynamic routes using recent almanac data. This product is offered as a cost-effective replacement for GPS repeaters along with many other uses including XM Weather Radar testing, stationary testing, and motion testing.

The product is offered in three configurations: single coupler, dual coupler and direct connect.



Figure 1-1 OSPREY Single Coupler Configuration (Front / Back)

The single coupler configuration includes a GPS coupler with the GPS Simulator Controller hardware collar. The GPS Simulator Controller will support connections to two couplers, so a dual coupler configuration will have one GPS Coupler with the GPS Simulator Controller cabled to a second GPS Coupler (with included shot bag).

The direct connect configuration will be the GPS Simulator Controller without any GPS couplers. This can be used for direct connecting to GPS devices or can be used with your existing GPS couplers (retrofit).

The OSPREY comes with a mobile application which supports both iOS and Android devices and is free to download from any app store. The application will allow you to create and manage waypoints and routes and also allow for rapid download of recent satellite almanac data. Once waypoints and routes are defined and almanac is updated, control of the OSPREY can be accomplished from the front panel of the OSPREY.

1.2 Principles of Operation

The OSPREY employs an 10-channel GPS L1 satellite simulator module that is capable of either static or dynamic simulation.

As with any GPS Simulator, the "almanac" data is what drives the simulation of all satellites or space vehicles (SVs). Almanac data is essentially a mapping of the locations of SVs at a given point in time. Weekly almanac data is supplied by the US Coast Guard and daily data in the form of a RINEX (Receiver Independent Exchange Format) file is supplied by NASA.

The OSPREY utilizes daily almanac data (RINEX) and extrapolates SV locations based on current UTC time and date. Thus, it is important that the almanac data used by the GPS simulator is recent. If your GPS receiver is not locking quickly, the almanac data may need to be updated.

1.3 Features and Capabilities

The OSPREY platform delivers the following features and capabilities:

- Compact, Rugged Design
- Global Avionics Test Set Support
- Fully Self-Contained
- Static and Dynamic simulations
- Automated Almanac upload process
- 10-channel configuration
- Remote control interface via mobile application for both iOS and Android devices
- Single, Dual Coupler or Retrofit Configurations
- GPS signals simulated: L1
- Direct Connect capability

1.4 Controls and Connectors

The OSPREY will be able to be controlled remotely from the mobile application which can be run on most phones or tablets.

Alternatively, once the mobile application has set up the waypoints and routes, control can be accomplished from the front panel of the OSPREY via up/down arrows and selection button.



Figure 1-2 Mobile application



Figure 1-3 OSPREY Front Panel Display / Control

Other connectors (see [Figure 1-1](#)) include the SMA and TNC connectors on the GPS Simulator Controller. The SMA connector is directly connected to the GPS Coupler that the controller is mounted on. The TNC connector is utilized to connect a 2nd GPS Coupler for the dual coupler configuration. To use in Direct Connect method, either the SMA or TNC connection can be used.



NOTE

When using TNC connection, DUAL MODE must be enabled in SETUP. on the mobile application.

There is also a USB-C connector that is used for recharging the two internal Lithium-Ion batteries with the provided AC adapter and USB-C cable. This USB-C cable can be used to update firmware in the field, as needed.

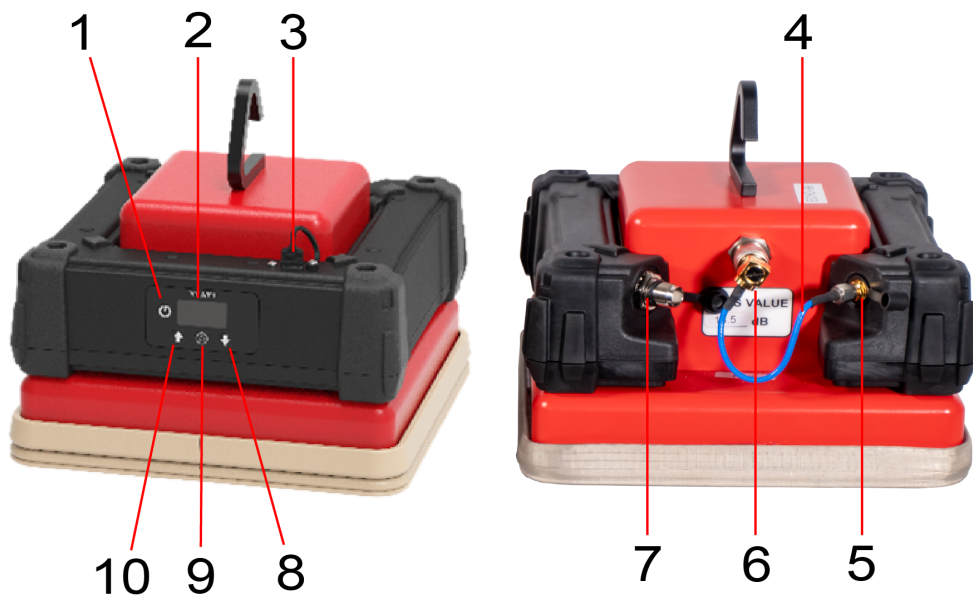

Figure 1-4 OSPREY Controls and Connectors

Table 1-1 OSPREY Controls and Connectors

Idx #	Connector	Description
1	Power ON/OFF	Powers the unit ON or OFF.
2	Front Panel Display	Displays the specific items or tasks on the menu.
3	Power Adapter 5V USB	USB C connection is used to charge the batteries.
4	Cable	SMA to TNC Cable

Table 1-1 OSPREY Controls and Connectors (Continued)

Idx #	Connector	Description
5	SMA Connector	Provides the simulated satellite signal to the main coupler.
6	TNC Connector	Provides the simulated satellite signal to the 2nd coupler for Dual Configuration or Direct Connect.
7	TNC Connector used for dual coupler	The TNC Connector on the OSPREY provides an output signal to the second coupler in the dual configuration. This output must be turned on in the mobile application to be active.
8	Down Arrow	Press the UP/DOWN arrow keys to select a specific task on the MENU.
9	Selection Button	Selects the specific item or task the arrow is pointing to.
10	Up Arrow	Press the UP/DOWN arrow keys to select a specific task on the MENU.

Setup, Control, and Operation

This chapter contains instructions for setting up the OSPREY GPS Simulator. This chapter also provides an overview of the device's User Interface (UI).

The topics discussed in this chapter are as follows:

- Upon Receipt 2-2
 - Unpack the Device 2-2
 - Verify and Inspect Contents 2-2
 - Verifying Shipment Contents. 2-2
- First Time Use 2-4
 - General 2-4
 - Powering the Device 2-4
 - Safety Precautions 2-4
 - Compliance Instructions 2-4
 - Battery Operation 2-4
 - Power On/Off Procedures 2-5
- Verify Operation 2-6
- Control and Operation 2-7
 - Verify Functional Operation. 2-7
- Screens 2-8
 - OSPREY GPS Simulator Screens 2-8
 - Mobile Application Screens. 2-10
- UI Navigation, Control and Layout. 2-11
- Input/Output Connectors 2-12
- Updating OSPREY Software 2-12

2.1 Upon Receipt

This section describes tasks that should be completed when a new OSPREY is received from the factory.

2.1.1 Unpack the Device

Special-design packing material inside this shipping carton provides maximum protection for the OSPREY. Avoid damaging the carton and packing material during equipment unpacking.

Use the following steps for unpacking the OSPREY. Use care not to damage the shipping container and packaging materials when unpacking the device: materials should be stored for possible future use.

1. Cut and remove sealing tape from the top of the shipping container.
2. Open shipping container. Remove foam inserts and device from shipping container.
3. Remove device from packing materials.
4. Place protective plastic bag and end cap packing material inside shipping carton.
5. Store packing material and shipping container for possible future use.

2.1.2 Verify and Inspect Contents

1. Check and verify the equipment against the packing slip to see if the shipment is complete. Report all discrepancies to VIAVI.
2. Inspect the equipment for damage incurred during shipment. If the equipment has been damaged, report the damage to VIAVI Solutions.

2.1.3 Verifying Shipment Contents

Verify the shipment is complete according to the items listed on the packing list. Accessories may be shipped in a separate box. Report any discrepancies to VIAVI.

2.1.3.1 Standard Hardware Components

The following items are included with the OSPREY:

Table 2-1 OSPREY Standard Items per Configuration

Part Number	Kit Contents	22186200 OSPREY-GPSIM	22186199 OSPREY-1 (Single)	22186198 OSPREY-2 (Dual)
22186200	OSPREY GPS Simulator	1	1	1
87676	GPS Antenna Coupler		1	2
22176099	Power Adapter 5V USB	1	1	1
22148009	Cable USB-A to USB-C	1	1	1
112830	Cable TNC-TNC 6'			1
88753	Shot Bag			1
22190483	Quick Start Guide	1	1	1
22189238	Case Single Coupler		1	
22189237	Case Dual Coupler			1

NOTICE: Only accessories which meet the manufacturer's specifications shall be used.

2.1.3.2 Recommended Optional Accessories

The following are optional accessories that VIAVI recommends purchasing for the OSPREY. Refer to the product data sheet for a complete list of available optional accessories.

Table 2-2 OSPREY Optional Accessories

Part Number	Description
22189092	Replacement Battery
90106	8 ft Coupler Pole with D-Ring
141131	25' TNC M/M Cable
141839	50' TNC M/M Cable



NOTE

Optional accessories may be included as standard accessories with some system configurations. See the packing list for shipment contents.

2.2 First Time Use

2.2.1 General

This section provides instructions for preparing the OSPREY GPS Simulator for operation when the device is received for use the first time.

The OSPREY GPS Simulator is powered by internal Lithium-Ion battery packs. The unit is supplied with an external Power Adapter and cable that enables the operator to recharge the battery when connected to AC power.

2.2.2 Powering the Device

Please read this section in its entirety before powering on the device.

2.2.3 Safety Precautions

The following safety precautions must be observed during installation and operation. VIAVI assumes no liability for failure to comply with any safety precaution outlined in this manual.

2.2.4 Compliance Instructions

Installation/operating personnel should not attempt to operate the OSPREY without reading and complying with instructions contained in this manual. All procedures contained in this manual must be performed in exact sequence and manner described.

2.2.5 Battery Operation

The OSPREY GPS Simulator is designed to be powered by internal batteries. The internal batteries support up to 12 hours of continuous operation, after which time the battery needs recharging. The percentage of remaining battery is shown in the on-screen information.

The batteries should be charged every three months (minimum) or disconnected for long-term inactive storage periods of more than six months. The batteries must be removed when conditions surrounding the OSPREY are $<-20^{\circ}\text{C}$ or $>60^{\circ}\text{C}$.

2.2.5.1 Battery Charging Operation

A battery charging indicator is displayed on the Controller User Interface screen. See [Figure 2-4](#). For the OSPREY GPS Simulator, the word "Charging" will be displayed on top line of text.



CAUTION

- Use only the AC Adapter/Charger supplied with the product
- The replacement part numbers:
USB-A to USB-C Cable - 22148009
USB-A Power Supply - 22190042
- Do not use the AC Adapter/Charger outdoors or in a wet or damp location
- Only connect the AC Adapter/Charger to the correct mains voltage indicated on the ratings

Charging the battery

1. Connect the power cord to the AC Adapter/Charger.
2. Connect the DC USB-C connector to the device's DC USB-C input connector.
3. Connect the power cord to a grounded AC power supply.

2.2.6 Power On/Off Procedures

The OSPREY GPS Simulator is powered ON and OFF using the Power button located on the front panel.

Turning the OSPREY ON

1. Press the Power button.

The Home Screen is displayed when the OSPREY is ready for use.

Turning the OSPREY OFF

1. Press the Power button.

The screen will turn off.

2.3 Verify Operation



NOTE

The following procedure is used to verify that the OSPREY GPS Simulator is operational.

When the OSPREY GPS Simulator is received from the factory, perform the following steps when using the device for the first time:

1. Download the OSPREY mobile application on a mobile device.
2. Turn the OSPREY GPS Simulator on and enter the System Info page to view the Device ID, i.e. 39B7CA6F.
3. Run the OSPREY application and on the initial page, connect to the OSPREY GPS Simulator to the Device ID that matches the hexadecimal value, i.e. "Osprey39B7CA6F".



Figure 2-1 OSPREY Display showing Device ID

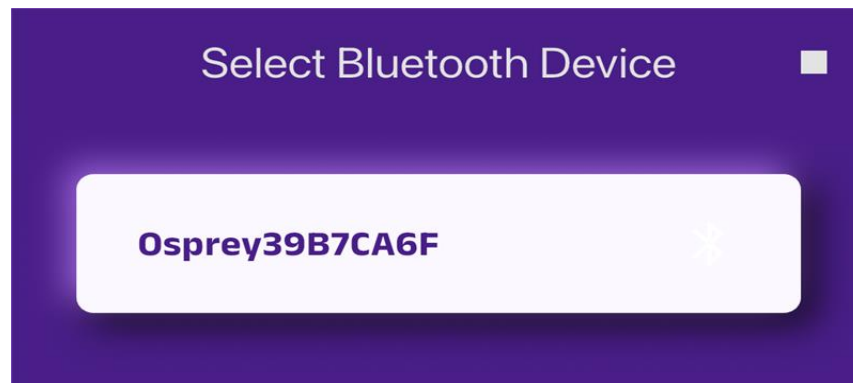

Figure 2-2 Mobile App connection screen

4. After the mobile application configures the OSPREY (~7 seconds), the home screen of the application should now show "Connected" and a green LED symbol.

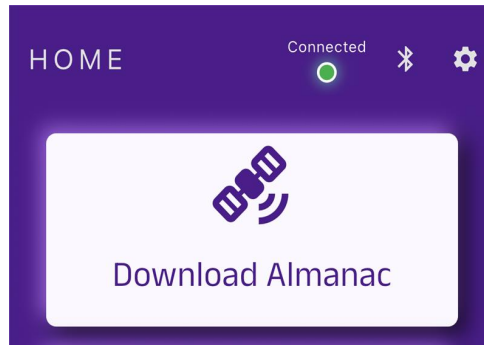

Figure 2-3 OSPREY Connected LED

5. If a connection cannot be made between the mobile application and the OSPREY controller, please contact VIAVI Technical Assistance Center (TAC) for technical support. See ["Contact Information"](#).

2.4 Control and Operation

The OSPREY GPS Simulator can be operated locally using the device's screen and buttons or remotely using any mobile device with VIAVI's OSPREY application which is available at any online application store.

2.4.1 Verify Functional Operation

Required Test Tools:

- R&S NRQ6 Frequency Selective Power Sensor (or equivalent)

For those customers that need to verify the functionality of incoming equipment, the following procedure is provided.

1. Connect the NRQ6 to the OSPREY SMA connector.
2. Tune NRQ6 settings to 1575.42 MHz.
3. Power up the OSPREY and connect the OSPREY mobile application to the OSPREY (as described in section above) and click on the settings icon in the upper right corner.
4. On the OSPREY mobile app settings page, set Operation Check to ON (to the right). This will turn on a CW signal at -90 dB.
5. Using the NRQ6, verify the output of power = 90 dB +/- 4 dB.
6. On the OSPREY mobile application, turn Operational Check off.
7. Close the OSPREY mobile application.

2.5 Screens

2.5.1 OSPREY GPS Simulator Screens

Table 2-3 OSPREY GPS Simulator Screens





	<p>OSPREY Home Screen Main screen that shows connectivity to Mobile Application, charging status, and provides access to Static Menu, Dynamic Menu, and System Info screens.</p>
	<p>OSPREY Static Menu Screen Static Menu screen that provides choices of waypoints to simulate and access to start the simulation.</p>
	<p>OSPREY Dynamic Menu Screen Dynamic Menu screen that provides choices of route to simulate and access to start the simulation.</p>
	<p>OSPREY System Info Screen System Info screen that shows ID of the controller hardware, firmware version, and battery charge.</p>

Table 2-4 OSPREY GPS Simulator Screens



OSPREY Charging Screen

When controller is plugged in to a charger, the top line of the main screen will indicate the charging status.



OSPREY Simulating Screen

When simulating, the screen will allow user to stop the simulation.

2.5.2 Mobile Application Screens

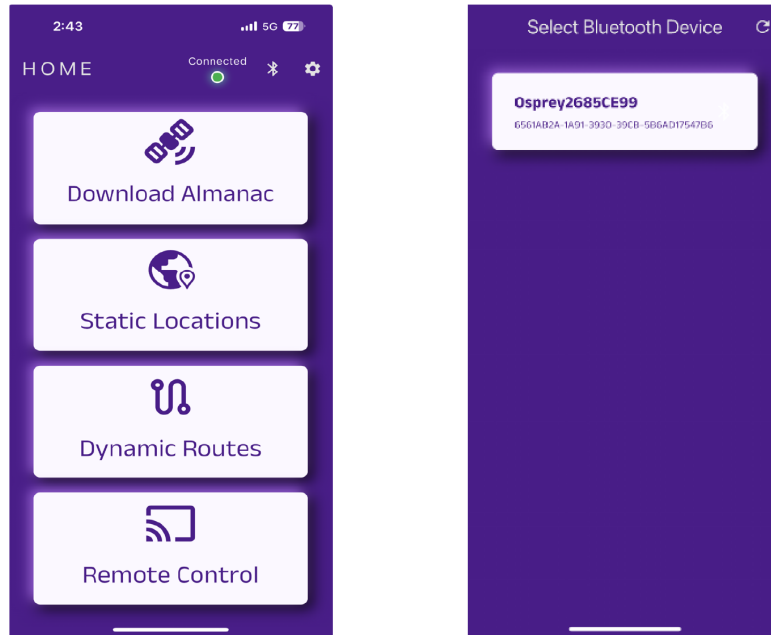

Figure 2-4 OSPREY Mobile App Home and Connection screens

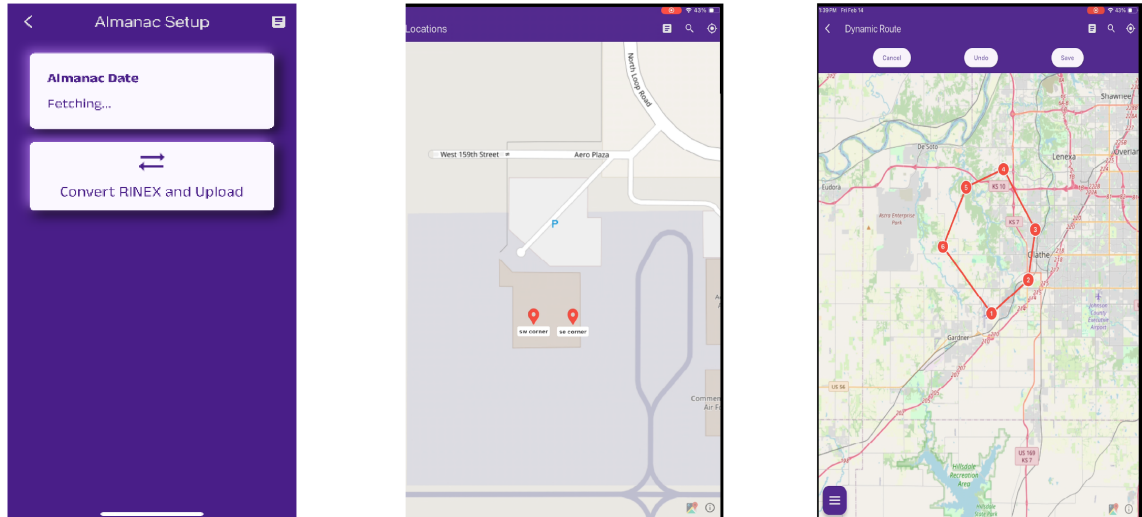

Figure 2-5 OSPREY Mobile App Almanac, Static and Dynamic screens

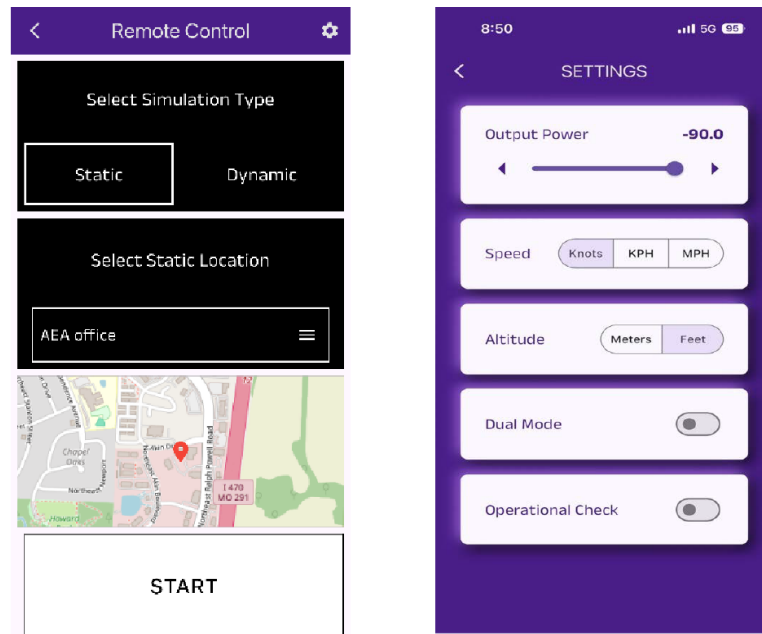

Figure 2-6 OSPREY Mobile App Remote Control and Settings screens

2.6 UI Navigation, Control and Layout

The front panel controls and buttons are used to operate and control the device, view data and navigate the user interface (UI).



Figure 2-7 Front panel controls and buttons

The power button provides ON/OFF control of the unit. The UP/DOWN arrows control the selection and the lower center button selects the item that is highlighted by the control arrow.

2.7 Input/Output Connectors

The OSPREY GPS Simulator is equipped with two RF connectors and one USB-C connector. The RF connectors support connection of the GPS Couplers. In the Single Coupler configuration only the smaller SMA RF connector is used. For the Dual Coupler configuration, the larger TNC connector will connect to a second GPS Coupler via the TNC cable provided in the kit. When directly connecting the OSPREY GPS Simulator module, either port can be used.



Figure 2-8 OSPREY I/O Connectors

The main purpose of the USB-C connector is to recharge the batteries. The USB-C connector can also be used for firmware updates.

2.8 Updating OSPREY Software

The OSPREY GPS Simulator firmware can be upgraded in the field. Should this be needed, Firmware and associated documentation is provided on the VIAVI website. The VIAVI OSPREY Mobile Application will be updated based on your mobile device settings.

System Settings Screens

This chapter provides a description of the OSPREY system functions and the controls and settings located on each screen. This chapter contains the following content:

- [System Settings Screens](#) 3-2



NOTE

See [Chapter 4 “Configuring System Settings”](#) for step-by-step instructions to configure various system settings.

3.1 System Settings Screens

The System Settings screen will provide control of the following parameters:

- Output Power: -145 to -90 dB
- Speed Units: select Knots, KPH or MPH
- Altitude Units: select meters or feet
- Dual Mode: Turn on when using two couplers. Leave Off for single coupler use.
- Operational Check: See section 2.4

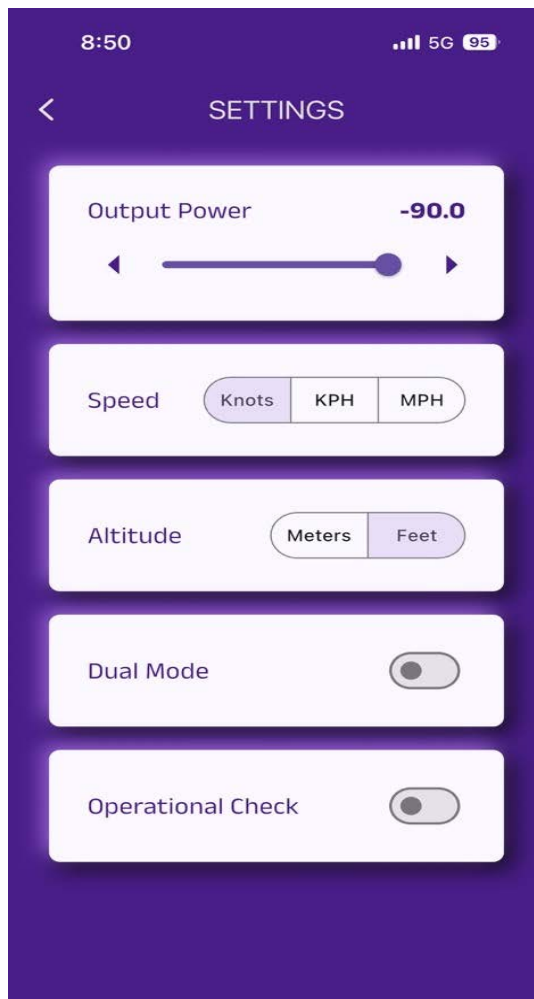

Figure 3-1 SettingsScreen

Configuring System Settings

This chapter contains information for various operation settings and includes the following sections:

- [Establishing Wireless Connection](#) 4-2
- [Remotely Operating the Device](#) 4-2

**NOTE**

See [Chapter 3 “System Settings Screens”](#), for detailed information about system functions.

4.1 Establishing Wireless Connection

Wireless connections from the mobile device can be controlled directly from the VIAVI OSPREY application. The initial screen will direct the user to connect to an OSPREY GPS Simulator. If you are unable to connect, or do not have an OSPREY GPS Simulator, the mobile application will not be usable.

On the initial connection screen, all OSPREY GPS Simulators that are powered on and within range will be displayed. Select the device ID associated with the OSPREY GPS Simulator in use. Once connected, you can come back to this screen to disconnect or can disconnect simply by closing the mobile application.

4.2 Remotely Operating the Device

Once the mobile application is connected to the OSPREY GPS Simulator, the application will display "Connecting..." and load the static waypoints and dynamic routes that are stored on the OSPREY GPS Simulator. While connected, the almanac data may be updated, static waypoints and dynamic routes can be added, edited, or deleted, and the OSPREY GPS Simulator can be remotely controlled.

GPS Simulator Functions

This chapter provides an overview of the GPS Simulator Functions. Contents in this chapter are as follows:

- [Almanac Download](#) 5-2
- [Create / Manage Static Waypoints](#) 5-3
- [Create / Manage Dynamic Routes](#) 5-4

5.1 Almanac Download

Selecting Download Almanac from the Home screen will allow you to update your almanac to the most recent data. The current date of your almanac will be displayed. Press Convert RINEX and Upload to begin the process. This process should take less than 2 minutes to complete. Once all satellite data is uploaded, the Almanac Date will reflect the current date.

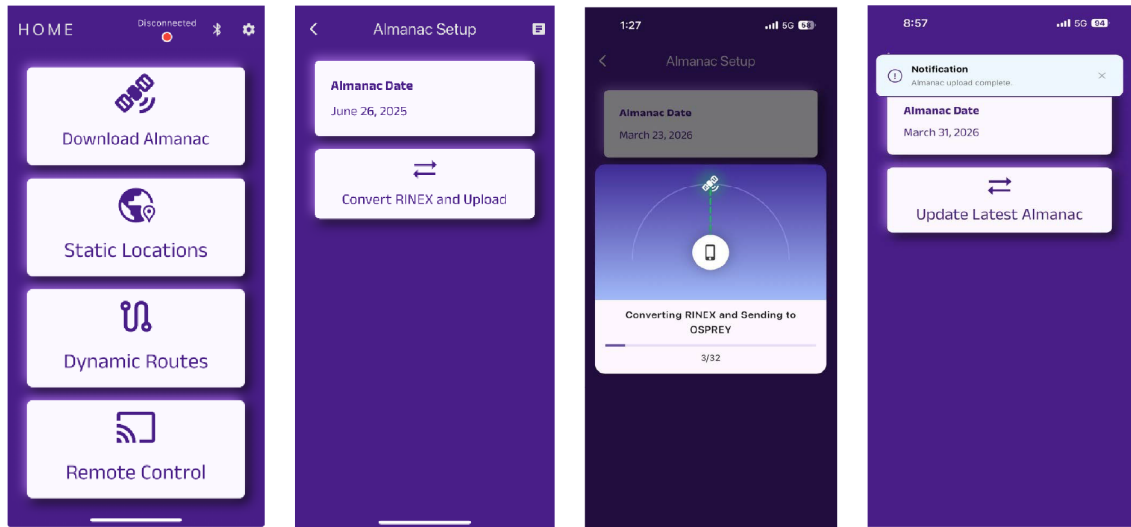

Figure 5-1 Selecting Download Almanac



NOTE

Ensure your device is using the Viavi Osprey app and has the correct date and time set.

If you manually role back your phones date/time the almanac will show your phones date and not the real date.

5.2 Create / Manage Static Waypoints

The mobile application will allow you to set up to fifteen static waypoints. To create a waypoint, click the Static Locations button from the Home screen, move the map to the desired location and press and hold for 2 seconds. This will pop up a screen with the Latitude and Longitude of your selected location (you will be able to edit and fine tune the location later). You can name this location and enter the desired altitude as well. If you press Save without entering anything, the name will be Pin1 (or next in line) and the altitude will be 0 ft.

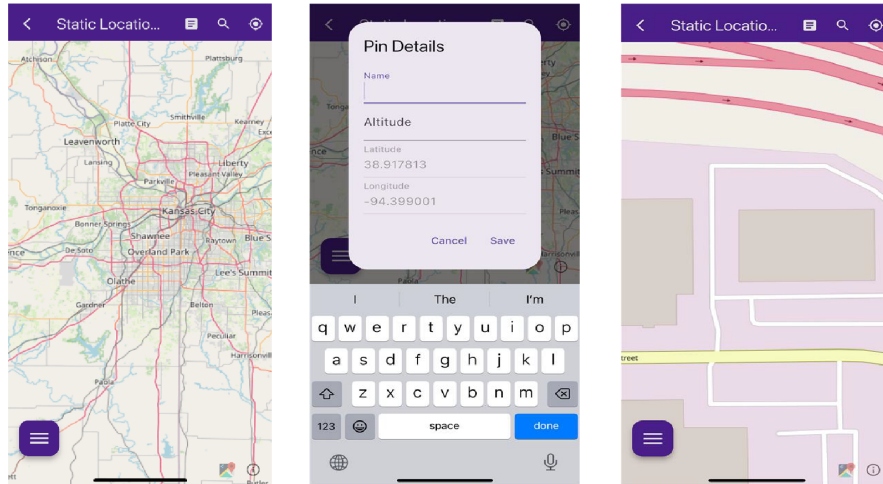

Figure 5-2 Create/Manage Static Waypoints

The magnifying glass in the upper right will allow you to search for a specific location and the target symbol will zoom in on your current location. The menu icon in the lower left will allow you to edit your waypoint list or delete the entire list.

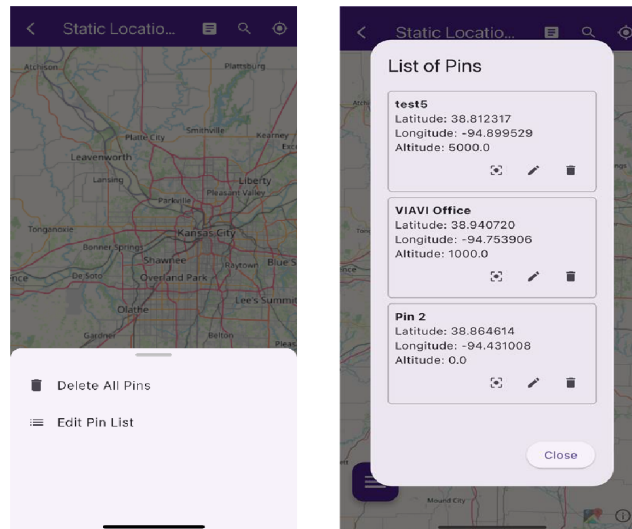

Figure 5-3 Create/Manage Static Waypoints 2

5.3 Create / Manage Dynamic Routes

Up to 10 Dynamic Routes can be created with up to 10 waypoints each. At this time, route speed and altitude are constant and are entered when first creating a route.

To create a Dynamic Route, click the Dynamic Routes button from the Home screen and then click Create button on the lower right of the screen. Enter the desired Speed and Altitude for this route. Then click at least two locations on the map to generate a valid route. You can Undo the previous step or cancel clear out of the creation process. As it is being created, the route will be checked for errors with each entry as waypoints cannot be extremely close to each other. When you are finished adding waypoints, press Save and name your route.

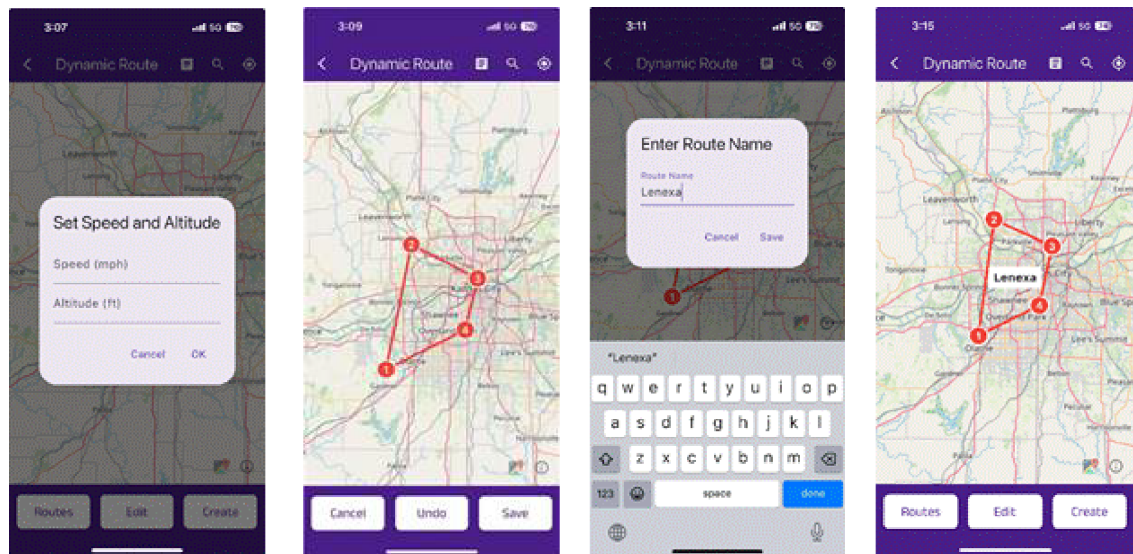

Figure 5-4 Create / Manage Dynamic Routes

Once the route is created, you can rename it by clicking the Routes button and edit pencil. On that screen, you can also delete the route from the list by clicking on the trash can.

To edit waypoints in an existing route, click the Edit button. Tap on a waypoint to manually adjust Latitude and Longitude or automatically adjust them by holding and dragging a waypoint on the map. Click "Done Editing" button when you are finished.

You can also edit the speed and altitude.

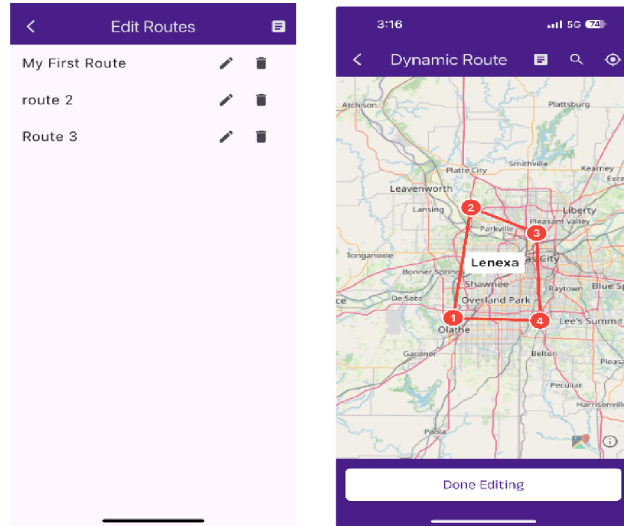

Figure 5-5 Create / Manage Dynamic Routes 2

This page intentionally left blank.

Performing Simulations

This chapter provides step-by-step instructions for configuring the OSPREY to perform the following tests:

- [Performing Simulations from the Mobile Application](#) 6-2
- [Performing Simulations from the OSPREY GPS Simulator](#) 6-4

6.1 Performing Simulations from the Mobile Application

For any GPS simulation, it is best practice to start the simulation with the OSPREY GPS Coupler(s) in place over the aircraft's GPS antenna with the aircraft GPS powered off. Once the simulation is running, apply power to the aircraft GPS so that the simulated signal is the first thing that it sees on power up.

Typically, a GPS Receiver will obtain lock within a couple of minutes. If you are having issues obtaining a GPS lock, this can be due to a number of issues.

- Additional isolation may be needed if testing outside or in a hangar with GPS repeaters
- Try cycling power to the GPS receiver
- Check your GPS LRU user's manual for GPS receiver cold-start procedures

To start a static simulation using the mobile application, press the Remote Control button at the bottom of the Home screen, leave the Static option selected, choose your location from the list of created waypoints and press the START button.

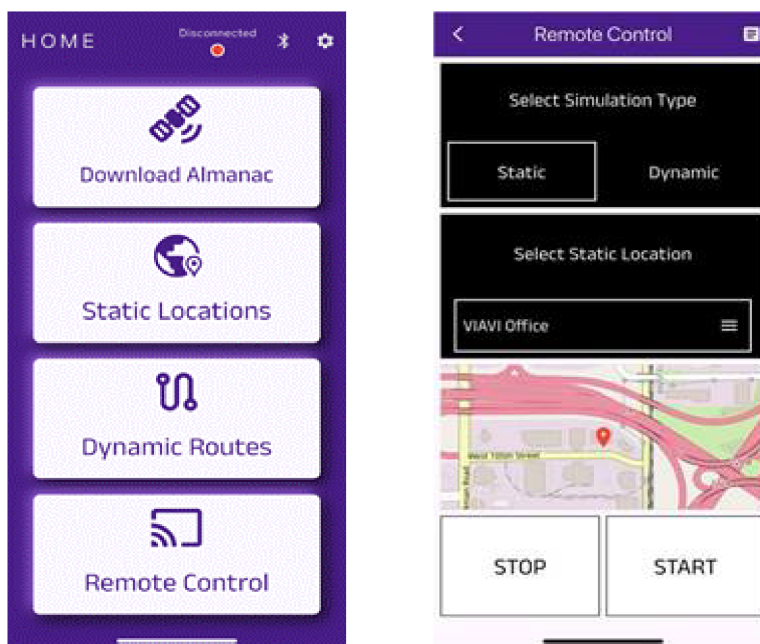

Figure 6-1 Performing Simulations from the Mobile Application

To start a dynamic simulation using the mobile application, press the Remote Control button at the bottom of the HOME screen, select the Dynamic option, choose the route from the list of created routes and then select between Loop Once or Continuous Looping.

The route will be automatically paused until the user presses RESUME. This gives the GPS Receiver the required time to obtain lock. Once the GPS Receiver is locked, press the RESUME button. Pressing STOP will stop the simulation.

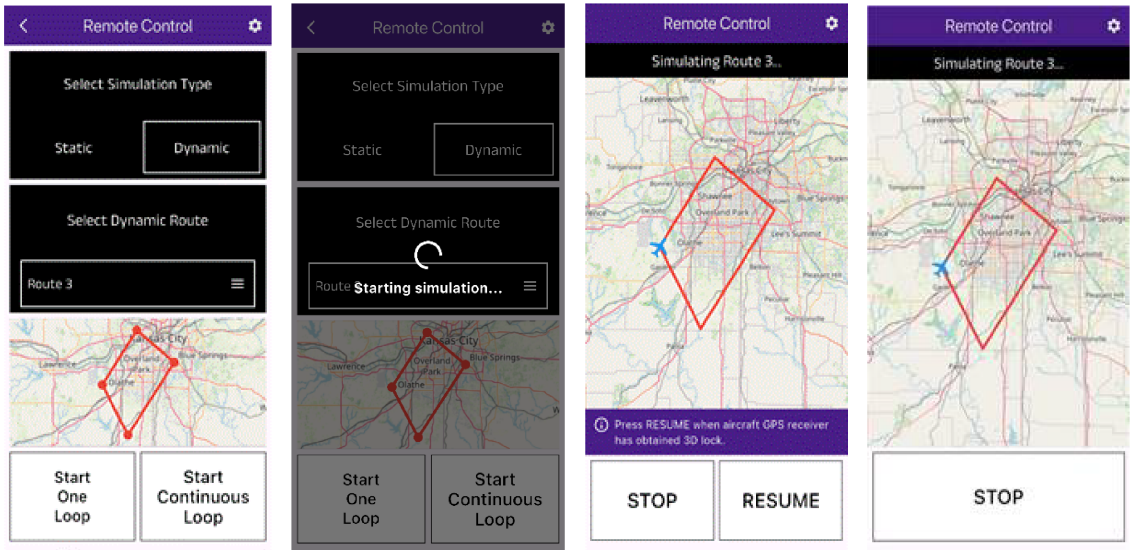

Figure 6-2 Performing Simulations from the Mobile Application 2



NOTE

The minimum number of locked satellites for a 3D fix is 4, but if more time is given to acquire as many as possible, your position accuracy will be increased.

6.2 Performing Simulations from the OSPREY GPS Simulator

To start a static simulation using the OSPREY GPS Simulator, press the UP/DOWN arrow keys until arrow is pointing at "Static Menu" and press the SELECTION Button. Use UP/DOWN arrows to select the waypoint to simulate and then press the center selection Button.



Figure 6-3 Static Simulation

To start a dynamic simulation using the OSPREY GPS Simulator, press the UP/DOWN arrow keys until arrow is pointing at "Dynamic Menu" and press the SELECTION Button. Use UP/DOWN arrows to select the route to simulate and then press the center selection Button.



Figure 6-4 Dynamic Simulation

Care and Maintenance

This chapter reviews storage and shipping instructions as well as care and maintenance procedures for the OSPREY. This chapter reviews the following topics:

- Storage Instructions 7-2
- Return Material Authorization (RMA) 7-2
- Shipping Instructions 7-2
- Operator Level Maintenance 7-3
 - Visual Inspections 7-3
 - External Cleaning 7-3
- Case/Cover Removal 7-4
- Battery Recharge 7-5
- Battery Replacement Instructions 7-6
 - Replacement Part Information 7-6
 - Tool Requirements 7-6
- Battery Replacement 7-7
 - Battery Part Information 7-7
 - Battery Removal 7-7
 - Battery Installation 7-9

7.1 Storage Instructions

The OSPREY should be stored in a clean, dry place according to current specifications.

See [Appendix A “OSPREY Specifications”](#)

7.2 Return Material Authorization (RMA)

Do not return any products to the factory without prior authorization from VIAVI. A Return Material Authorization (RMA) can be obtained from VIAVI Customer Service.

Request RMA

1. Go to the following website:
<https://www.viavisolutions.com/en-us/support/customer-support/return-material-authorization-rma-request>
2. Request a Return Material Authorization (RMA) number.
3. For general information:
<https://www.viavisolutions.com/en-us/general-shipping-instructions-avionics>

7.3 Shipping Instructions

Any device returned to factory for calibration, service or repair must be repackaged and shipped subject to the following conditions:

1. For general shipping information, go to the following website:
<https://www.viavisolutions.com/en-us/general-shipping-instructions-avionics>
2. Ensure items are packaged in an appropriate container.
 - Devices should be repackaged in original shipping containers using VIAVI packing materials
 - If original shipping containers and materials are not available, contact VIAVI for suitable shipping instructions.



NOTE

- Freight companies may not honor insurance claims if items are not properly packaged
- Failure to properly package items being returned to VIAVI for warranty repair voids the VIAVI product warranty

3. Ensure items shipped to VIAVI are tagged with the following:
 - Owner's Identification and contact information
 - Nature of service or repair needed
 - Model Number and Serial Number
 - Return Authorization (RA) Number
4. Freight Costs
 - All freight costs on non-warranty shipments are assumed by the customer
 - VIAVI recommends that customers obtain freight insurance with the freight carrier when shipping the Device
 - VIAVI is not responsible for cost of repairs for damages that occur during shipment on warranty or non-warranty items

7.4 Operator Level Maintenance

The following procedures may be performed by the Operator. All other service must be performed by Qualified Service Personnel.



WARNING

Do not operate this Device with the case/cover open. Opening the case/cover exposes the operator to electrical hazards which can result in electrical shock or damage to the Device.

7.4.1 Visual Inspections

Visual inspections should be performed periodically depending on operating environment, maintenance and use.

- Check for presence and condition of all warning labels and markings and supplied safety information
- Inspect connectors for dirt, dust, corrosion or rust
- Inspect the device and accessories for damage. Do not use if there is damage to the exterior of the unit or power accessories

7.4.2 External Cleaning

- Remove grease, fungus and ground-in dirt from surfaces with soft lint-free cloth dampened (not soaked) with isopropyl alcohol
- Remove dust and dirt from connectors with soft-bristled brush
- When not in use, cover the connectors with suitable dust cover to prevent tarnishing of connector contacts

7.4.2.1 ****ESD**** Precautions



CAUTION

This Device is **** ESD **** sensitive and should only be installed, removed and/or serviced by Qualified Service Personnel.

7.4.2.2 **Battery Handling and Disposal**



WARNING

Lithium-Ion batteries are used in this device. Lithium is a toxic substance.

- Do not crush, incinerate or dispose of in normal waste.
- Do not short circuit or force discharge since this might cause the battery to vent, overheat or explode.

Please read [“Safety and Compliance Information”](#) in its entirety for information on Battery Safety, Handling and Disposal.

7.5 **Case/Cover Removal**

Do not operate this device with the case or covers removed.



CAUTION

Servicing should only be performed by Qualified Service Personnel.

7.6 Battery Recharge

The OSPREY is designed to be powered by two internal batteries. The batteries supports up to 12 hours of continuous operation, after which time, the batteries needs recharging.

To Recharge the Batteries

1. Connect the power cord to the AC Adapter/Charger.
2. Connect the DC connector to the device's DC Input Connector (see "DC Input Connector" on page 5).
3. Connect the power cord to an AC power supply.
Verify the device's display indicates that the batteries are charging



CAUTION

- Do not use the power cord if it is damaged or frayed. Replace damaged power cords with cord of the same ratings
- Do not position the power cord in a manner that makes it difficult to disconnect from the main voltage
- Do not allow anything to rest on the power cord
- Do not locate the product where persons can walk on or trip over the power cord

7.7 Battery Replacement Instructions

The following procedure is an Operator Level Maintenance Procedure.

7.7.1 Replacement Part Information

7.7.1.1 AC Adapter/Charger



WARNING

Only Replace the battery with the Viavi Approved replacement part. 22189092; OSPREY-BATT; Battery.



CAUTION

- Only use the AC Adapter/Charger supplied with the instrument
- Do not use the AC Adapter/Charger outdoors or in a wet or damp location
- Only connect the AC Adapter/Charger to the correct mains voltage indicated on the ratings label

Table 7-1 Battery and Adapter Cord Replacement Part Numbers

Part Number	Description
2302-8490.019	Universal AC Power Adapter
22148009	USB-A to USB-C Cable
22189092	Rechargeable Lithium-Ion Battery

7.7.2 Tool Requirements

Table 7-2 Tool Requirements

TOOL	SIZE
Phillips Screwdriver	#2

7.8 Battery Replacement

7.8.1 Battery Part Information



WARNING

The two batteries supplied with the device should only be replaced with a VIAVI approved replacement part.

Table 7-3 Battery Replacement Part Number

Part Number	Description	Qty
22189092	Rechargeable Lithium-Ion Battery	2



WARNING

Lithium-Ion batteries are used in this equipment. Lithium is a toxic substance.

- Do not crush, incinerate or dispose of in normal waste.
- Do not short circuit or force discharge since this might cause the battery to vent, overheat or explode.

7.8.2 Battery Removal

The following procedure describes how to remove the batteries.

To Remove the two Batteries.



NOTE

VIAVI recommends powering down the device to replace the two batteries.

1. Place the OSPREY on a suitable work bench with the top facing down.
2. Loosen and remove 12 screws that secure the base cover to the main frame.
3. Remove bottom cover of the unit and carefully avoid damaging the PCB assembly.

Continued on next page.



CAUTION

Do not remove the battery using the cable but remove by grasping the battery body.

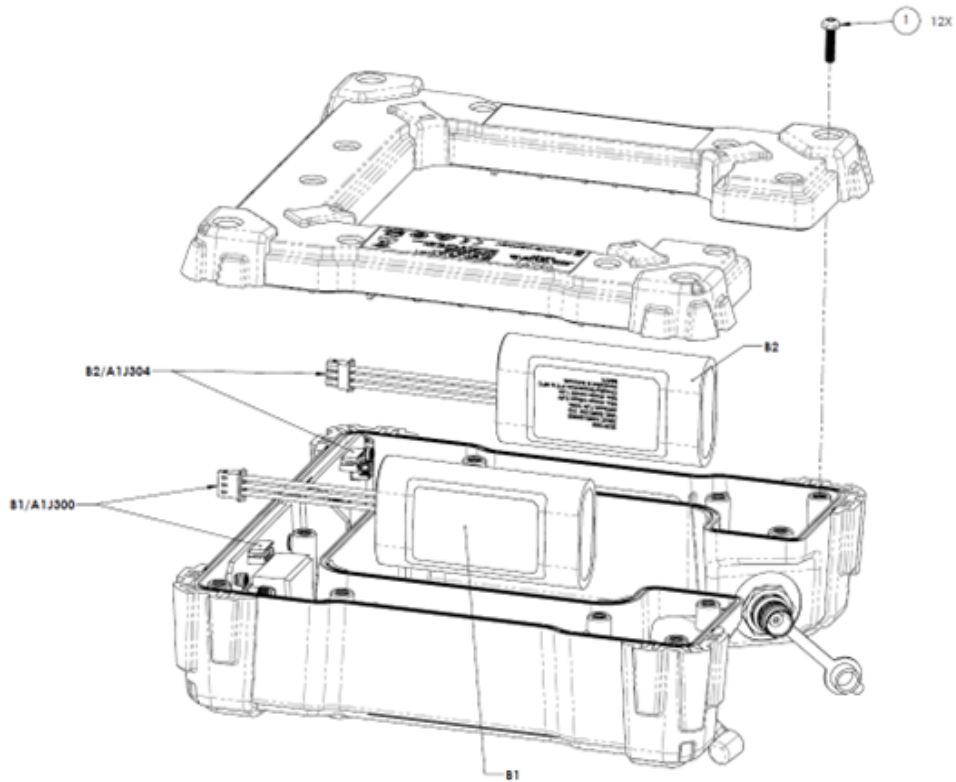

Figure 7-1 Base Cover Removal

4. Push tab on battery cable connector clip to release and pull cable away from connector. Remove batteries from the device. Refer to the section titled "Battery Handling and Disposal" for proper disposal of the batteries.

7.8.3 Battery Installation



WARNING

The batteries that came with the Osprey are Lithium-Ion batteries. Lithium-Ion batteries can explode or catch fire if damaged, or installed incorrectly, due to their high energy and flammable components, leading to dangerous "thermal runaway".

Always use the correct, manufacturer-specified batteries, insert them carefully, avoid physical damage (drops, punctures), keep them away from heat, and stop using immediately if swollen, hot, or leaking to prevent serious fire hazards.

1. Insert the new battery in the battery compartment.



CAUTION

When installing the new battery, use care to ensure wires are inside the compartment. Damage may occur if wires become pinched when installing the base cover.

2. Install the base cover. Connect the base cover to the Mainframe by aligning the parts and verify the baseplate is flush on the Mainframe before proceeding.
3. Replace Screws. Install the 12 screws to secure the base cover to the main frame.
4. Dispose of the old battery according to local regulations.

This page intentionally left blank.

OSPREY Specifications

This section contains specifications for standard OSPREY GPS Simulator. Refer to the OSPREY product data sheet for the full performance specifications.

- [Specifications](#) A-2

General Specifications

Dimensions 7.0"(177.8mm) x 7.0"(177.8mm) x 2.5"(63.5mm)

Weight 1.8 lbs

Display 0.96"(24.38mm) White OLED

Environmental

Operating Temperature: -10C to 55C

Non-Operating: -20C to 60C

Drop/Bench Handling: MIL-PRF-28800F Class 3

Battery

Type: 7.3V, 2.6 Ah x 2 (Lithium-Ion)

Operating temperature: -20 °C to +60 °C battery temperature

Charging temperature: 0 °C to +45 °C battery temperature

Storage temperature: -20 °C to +60 °C

Weight: 0.42 lbs.

Runtime: > 12 Hours

Compliance:

EMC: IEC/EN 61326-1, 2nd Edition: 2017; CISPR11:2015 +A1:2016

Safety: EN 61010-1, 3rd Edition

Ports

RF Output

Port 1 Type: SMA
Impedance: 50 Ω

Port 2 Type: TNC
Impedance: 50 Ω

Power

J1 Type: USB-C

RF Generator

Frequency 1575.42MHz

Amplitude

RF Out:

Range: -145 to -90 dBm

Resolution: 1.0 dB

OSPREE GPS Simulator Operation Manual
Specifications

Interfaces

Bluetooth

Range: > 50ft

USB

Mode Test and Debug only

Key Features

- On Screen Battery Indicator
- Real Time Clock
- Single or Dual Output selection
- Firmware update via USB

Abbreviations

Appendix B contains OSPREY Abbreviations

- [Appendix B. Abbreviations](#) B-2

Appendix B. Abbreviations

Table B-1 Appendix B Abbreviations

Term	Description
AC	Alternating Current
ANT	Antenna
ARB	Arbitrary Waveform Generator
BOM	Bill of Materials
Cal	Calibration
dB	deci-Bel (decibel)
DC	Direct Current
DWG	Drawing
EMI	Electromagnetic Interference
ERP	Effective Radiated Power
ESD	Electro Static Discharge
FOD	Foreign Objects & Debris
FPGA	Field Programmable Gate Array
GEN	Generator
GHz	Giga-Hertz
GLS	GNSS Landing System
GPS	Global Positioning System
Hz	Hertz
I/O	Input/Output
KHz	Kilo-Hertz (kHz)
LAT	Latitude
LONG	Longitude
MHz	Mega-Hertz
MTL	Mean Trigger Level
P/N	Part Number
RF	Radio Frequency
RF/IO	Radio Frequency I/O

Table B-1 Appendix B Abbreviations

Term	Description
UI	User Interface
USB	Universal Service Bus
Ver	Verification
VGA	Video Graphics Adapter
VHF	Very High Frequency
VNC	Virtual Network Computing

This page intentionally left blank.



OSPREY GPS Simulator
Operation Manual
22190377 Rev. 002
May, 2026
English

VIAVI Solutions

North America:	1.844.GO VIAVI / 1.844.468.4284
Latin America	+52 55 5543 6644
EMEA	+49 7121 862273
APAC	+1 512 201 6534
All Other Regions:	viavisolutions.com/contacts