



**XPDR/DME
TCAS/ADS-B/TIS/UAT
TEST SET
IFR 6000**

Getting Started Manual



GETTING STARTED MANUAL

XPDR/DME/TCAS/ADS-B/TIS/TIS-B/UAT TEST SET IFR 6000

PUBLISHED BY
VIAVI Solutions, Inc.

COPYRIGHT © VIAVI Solutions, Inc. 2019

All rights reserved. No part of this publication may be reproduced, stored in a retrieval system, or transmitted in any form or by any means, electronic, mechanical, photocopying, recording or otherwise without the prior permission of the publisher.

Original Printing	Aug 2009
Issue 1	Mar 2014
Issue 2	Apr 2014
Issue 3	Oct 2014
Issue 4	Nov 2016
Issue 5	Nov 2019

THIS PAGE INTENTIONALLY LEFT BLANK.

This manual contains essential information relating to initial use of the unit.

VIAVI recommends the operator become familiar with the Operation Manual contained on the accompanying CD-ROM.

VIAVI updates Test Set software on a routine basis. As a result, examples may show images from earlier software versions. Images are updated when appropriate.

THIS PAGE INTENTIONALLY LEFT BLANK.

Dear Customer,

Thank you for purchasing this test instrument. VIAVI takes pride in the products that it manufactures. In designing instruments with leading edge technology, and building instruments using state of the art manufacturing processes, VIAVI aims to build a reliable, robust, functional and 'fit for purpose' test instrument.

If, for some reason, your test instrument does not reach you in perfect working order, or you have any questions about your test instrument, please do not hesitate to contact the sales office where you originally purchased your instrument, or contact one of our VIAVI Regional Support Centers using the contact information below:

Americas:	
Tel:	[+1] 800-835-2350 Toll Free (US Only)
	[+1] (316)-529-5511
Fax:	866-325-1180 Toll Free (US Only)
	[+1] (316) 529-5330
avcomm.service@viavisolutions.com	

EMEA:	
Tel:	[+44] (0) 23 8027 3722
FAX:	[+44] (0) 23 8025 4015

VIAVI also offers extended warranty contracts, which enable you to lock in maintenance cost savings when you purchase a new instrument. If you did not take this option at the time of your initial sale, VIAVI is pleased to extend the same offer for 90 days from the date of your product delivery. For information about extended warranty options and pricing, contact the sales office where you originally purchased your instrument, or contact one of our VIAVI Regional Support Centers using the contact information above.

If you decide not to participate in one of our extended warranty programs and the manufacturer's warranty has expired, VIAVI offers a number of additional support options. These support programs are designed for maintenance cost predictability and cost containment in easy to use convenient packages. For more in depth information on any VIAVI support package, please contact 1-800-835-2350, or (316)-529-5511, contact us via Avcomm.service@viavisolutions.com, or visit our web site at www.viavisolutions.com.

Thank You,

The VIAVI Customer Support Team

STANDARD HARDWARE WARRANTY

THIS WARRANTY APPLIES ONLY TO PRODUCTS MANUFACTURED AT THE WICHITA AND STEVENAGE LOCATIONS.

VIAVI warrants, under customary use and service, the hardware product to be free from defects in material and workmanship for a period of TWO (2) YEARS from the shipping date. In addition, battery packs and external optional equipment have a 90-day warranty. This period shall be referred to as "The Standard Limited Warranty Period."

VIAVI's obligation under this warranty is limited to replacing or repairing, at VIAVI's option, free of charge except for certain freight charges as described herein, any defective part or parts of the instrument. If the instrument is found not to be defective in material or workmanship, or in the event the warranty claim is invalid because of failure to comply with the provisions herein, VIAVI shall notify the customer and shall only repair or replace the instrument parts at customer's direction and expense.

The warranty does not apply to any instrument that has been subject to misuse, alteration, negligence, accident, shipping damage, improper installation, or improper operation, or that in any way has been tampered with or repaired by any person other than an authorized VIAVI service organization or any employee thereof, or to any instrument whose serial number has been altered, defaced or removed. Annual certified calibration is not included in the warranty.

VIAVI shall not be liable for any delay or failure to repair or furnish a replacement part, including but not limited to, delays resulting directly or indirectly from any governmental restriction, priority, or allocation, or any other governmental regulatory order or action, nor shall VIAVI be liable for damages (direct, indirect, or consequential) by reason of the failure of the instrument to perform properly.

VIAVI performed repairs shall be warranted from defective material and workmanship for NINETY (90) DAYS or until the end of the Standard Limited Warranty Period whichever is longer. Risk of loss or damage to Product returned to VIAVI for repair or replacement shall be borne by customer until delivery to VIAVI. Upon delivery of such product, VIAVI shall assume the risk of loss or damage until such time as the product being repaired or replaced is returned and delivered to customer. Customer shall pay all transportation costs for equipment or software shipped to VIAVI for repair or replacement. VIAVI shall pay all transportation costs associated with returning repaired or replaced product to customer.

This warranty shall, at VIAVI's option, become void if the equipment ownership is transferred, unless the prior owner or the proposed owner obtains approval from VIAVI of continuation of the warranty prior to the transfer of ownership.

THIS WARRANTY IS IN LIEU OF ALL OTHER WARRANTIES, EXPRESS OR IMPLIED, INCLUDING ANY IMPLIED WARRANTY OF MERCHANTABILITY AND FITNESS FOR A PARTICULAR PURPOSE NOT SET FORTH IN WRITING SIGNED BY AN AUTHORIZED REPRESENTATIVE OF VIAVI INCORPORATED.

STANDARD SOFTWARE WARRANTY

THIS WARRANTY APPLIES ONLY TO PRODUCTS MANUFACTURED AT THE WICHITA AND STEVENAGE LOCATIONS.

VIAVI warrants that Software Products licensed to Customer shall, under normal use and service, and for a period of ninety (90) days from the date of shipment of the Software to Licensee (the "Standard Limited Warranty Period"), perform in all material respects in accordance with the published specifications for such Software as established by VIAVI. However, VIAVI does not warrant that the Software will operate uninterrupted or error free, operate in the combination with other software, meet Customer's requirements, or that its use will be uninterrupted.

THIS WARRANTY IS IN LIEU OF ALL OTHER WARRANTIES, EXPRESS OR IMPLIED, INCLUDING ANY IMPLIED WARRANTY OF MERCHANTABILITY AND FITNESS FOR A PARTICULAR PURPOSE NOT SET FORTH IN WRITING SIGNED BY AN AUTHORIZED REPRESENTATIVE OF VIAVI INCORPORATED.

THIS PAGE INTENTIONALLY LEFT BLANK.

SAFETY FIRST: TO ALL OPERATIONS PERSONNEL

REFER ALL SERVICING OF UNIT TO QUALIFIED TECHNICAL PERSONNEL. THIS UNIT CONTAINS NO OPERATOR SERVICEABLE PARTS.

WARNING: USING THIS EQUIPMENT IN A MANNER NOT SPECIFIED BY THE ACCOMPANYING DOCUMENTATION MAY IMPAIR THE SAFETY PROTECTION PROVIDED BY THE EQUIPMENT.

CASE, COVER OR PANEL REMOVAL

Opening the Case Assembly exposes the operator to electrical hazards that can result in electrical shock or equipment damage. Do not operate this Test Set with the Case Assembly open.

SAFETY IDENTIFICATION IN TECHNICAL MANUAL

This manual uses the following terms to draw attention to possible safety hazards that may exist when operating or servicing this equipment.

CAUTION: THIS TERM IDENTIFIES CONDITIONS OR ACTIVITIES THAT, IF IGNORED, CAN RESULT IN EQUIPMENT OR PROPERTY DAMAGE (E.G., FIRE).

WARNING: THIS TERM IDENTIFIES CONDITIONS OR ACTIVITIES THAT, IF IGNORED, CAN RESULT IN PERSONAL INJURY OR DEATH.

SAFETY SYMBOLS IN MANUALS AND ON UNITS



CAUTION: Refer to accompanying documents. (This symbol refers to specific CAUTIONS represented on the unit and clarified in the text.)



AC OR DC TERMINAL: Terminal that may supply or be supplied with AC or DC voltage.



DC TERMINAL: Terminal that may supply or be supplied with DC voltage.



AC TERMINAL: Terminal that may supply or be supplied with AC or alternating voltage.

EQUIPMENT GROUNDING PRECAUTION

Improper grounding of equipment can result in electrical shock.

USE OF PROBES

Check the specifications for the maximum voltage, current and power ratings of any connector on the Test Set before connecting it with a probe from a terminal device. Be sure the terminal device performs within these specifications before using it for measurement, to prevent electrical shock or damage to the equipment.

POWER CORDS

Power cords must not be frayed, broken nor expose bare wiring when operating this equipment.

USE RECOMMENDED FUSES ONLY

Use only fuses specifically recommended for the equipment at the specified current and voltage ratings.

SAFETY FIRST: TO ALL OPERATIONS PERSONNEL (cont)

INTERNAL BATTERY

This unit contains a Lithium Ion Battery, serviceable only by a qualified technician.

CAUTION: SIGNAL GENERATORS CAN BE A SOURCE OF ELECTROMAGNETIC INTERFERENCE (EMI) TO COMMUNICATION RECEIVERS. SOME TRANSMITTED SIGNALS CAN CAUSE DISRUPTION AND INTERFERENCE TO COMMUNICATION SERVICES OUT TO A DISTANCE OF SEVERAL MILES. USERS OF THIS EQUIPMENT SHOULD SCRUTINIZE ANY OPERATION THAT RESULTS IN RADIATION OF A SIGNAL (DIRECTLY OR INDIRECTLY) AND SHOULD TAKE NECESSARY PRECAUTIONS TO AVOID POTENTIAL COMMUNICATION INTERFERENCE PROBLEMS.

TABLE OF CONTENTS

Service Upon Receipt of Material	2
Specifications	5
Installation	6
Controls, Connectors and Indicators	9
Auxiliary Equipment	14
Screen Hierarchy	16
Self Test	21
Battery/Voltage Instructions	25
Fuse Replacement	29
Battery Replacement	30

SERVICE UPON RECEIPT OF MATERIAL

UNPACKING

Special-design packing material inside this shipping carton provides maximum protection for the IFR 6000. Avoid damaging the carton and packing material during equipment unpacking. Use the following steps for unpacking the IFR 6000.

- Cut and remove the sealing tape on the carton top and open the carton.
- Grasp the IFR 6000 transit case firmly, while restraining the shipping carton, and lift the equipment and packing material vertically.
- Place the IFR 6000 transit case and end cap packing on a suitable flat, clean and dry surface.
- Remove the protective plastic bag from the IFR 6000 transit case.
- Place protective plastic bag and end cap packing material inside shipping carton.
- Store the shipping carton for future use should the IFR 6000 need to be returned.

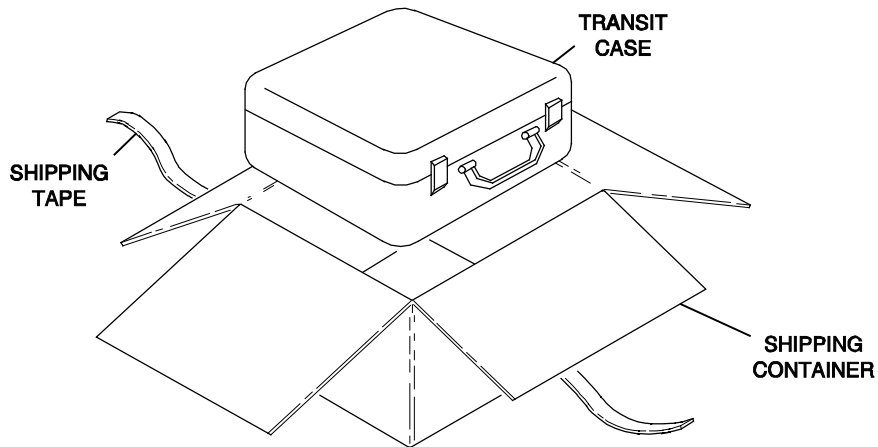

056P-05

SERVICE UPON RECEIPT OF MATERIAL (cont)

CHECKING UNPACKED EQUIPMENT

- Inspect the equipment for damage incurred during shipment. If the equipment has been damaged, report the damage to VIAVI.
- Check the equipment against the packing slip to see if the shipment is complete. Report all discrepancies to VIAVI.

DESCRIPTION	PART NUMBER	QTY
IFR 6000	72422	1
Power Supply	67366	1
Antenna	112684	1
Breakout Box	64580	1
Antenna Shield	64749	1
12 IN. Coaxial Cable (Antenna)	62401	1
72 IN. Coaxial Cable (Antenna)	112830	1
5 A Fuse	56080	1
Transit Case	10241	1
Power Cord (US only)	62302	1
POWER CORD (EUROPEAN)	64020	1
Operation Manual (CD-ROM)	6093	1
Getting Started Manual (Paper)	6096	1



IFR 6000 with Standard Accessories

SERVICE UPON RECEIPT OF MATERIAL (cont)
CHECKING UNPACKED EQUIPMENT (cont)

OPTIONAL ACCESSORIES	PART NUMBER	QTY
Desk Top Stand	63656	1
Tripod	67474	1
Tripod, Dolly, Stand	82553	1
25 ft TNC/TNC COAXIAL CABLE	62462	1
50 ft TNC/TNC COAXIAL CABLE	86336	1
UC-584 Dual Antenna Coupler Kit	112349	1
UC-584 Single Antenna Coupler Kit	112350	1
12 IN. COAXIAL CABLE (GPS)	112831	1
72 IN. Coaxial CABLE (GPS)	112837	1
IFR-6000 Maintenance Manual-(CD-ROM)	6095	1



Antenna Coupler and Cable

SPECIFICATIONS

Input Power (Test Set):

Input Range:	11 to 32 Vdc
Power Consumption:	55 W Maximum 16 W Nominal at 18 Vdc with Charged Battery
Fuse Requirements:	5 A, 32 Vdc, Type F

Input Power (External AC to DC Converter):

Input Range:	100 to 250 VAC, 1.5 A Maximum, 47 to 63 Hz
Main Supply Voltage Fluctuations:	≤10% of the nominal voltage
Transient Overvoltages:	According to Installation Category II

Environmental (Test Set):

Use:	Pollution Degree 2
Altitude:	≤4800 meters
Operating Temperature:	-20°C to 55°C (Battery Charging temperature range is 5°C to 40°C, controlled by internal charger)
Storage Temperature:	-30° to 70°C (Li Ion Battery must be removed when <-20°C and >60°C)
Relative Humidity:	
5°C to 30°C:	95%
30°C to 40°C:	75%
40°C to 55°C:	45%

Environmental (External AC to DC Converter):

Use:	Indoors
Altitude:	≤10,000 meters
Temperature:	
Operating:	0°C to 40°C
Storage:	-20°C to 71°C

INSTALLATION

GENERAL

The IFR 6000 is powered by an internal Lithium Ion battery pack. The Test Set is supplied with an external DC Power Supply that enables the operator to recharge the battery when connected to AC power.

NOTE: The IFR 6000 can operate continuously on AC power via the DC Power Supply, for servicing and/or bench tests.

BATTERY OPERATION

The internal battery is equipped to power the IFR 6000 for more than four hours of continuous use, after which time, the IFR 6000 battery needs recharging. Battery Operation Time Remaining (in Hours) is displayed on all screens.

The IFR 6000 contains an automatic time-out to conserve power. If a key is not pressed within a 5 to 20 minute time period, the Test Set shuts Off (only when using battery power). The Power Down Time may be set in the Setup Screen.

BATTERY CHARGING

The battery charger operates whenever DC power (11 to 32 Vdc) is applied to the Test Set with the supplied DC Power Supply or a suitable DC power source. When charging, the battery reaches a 100% charge in approximately four hours. The internal battery charger allows the battery to charge between a temperature range of 5° to 40°C. The IFR 6000 can operate, connected to an external DC source, outside the battery charging temperature range (5° to 40°C).

The battery should be charged every three months (minimum) or disconnected for long term inactive storage periods of more than six months. The Battery must be removed when conditions surrounding the Test Set are <-20°C and >60°C)

SAFETY PRECAUTIONS

The following safety precautions must be observed during installation and operation. VIAVI assumes no liability for failure to comply with any safety precaution outlined in this manual.

Complying with Instructions

Installation/operating personnel should not attempt to install or operate the IFR 6000 without reading and complying with instructions contained in this manual. All procedures contained in this manual must be performed in exact sequence and manner described.

Grounding Power Cord

WARNING: DO NOT USE A THREE-PRONG TO TWO-PRONG ADAPTER PLUG. DOING SO CREATES A SHOCK HAZARD BETWEEN THE CHASSIS AND ELECTRICAL GROUND.

For AC operation, the AC Line Cable, connected to the DC Power Supply, is equipped with standard three-prong plug and must be connected to a properly grounded three-prong receptacle that is easily accessible. It is the customer's responsibility to:

- Have a qualified electrician check receptacle(s) for proper grounding.
- Replace any standard two-prong receptacle(s) with properly grounded three-prong receptacle(s).

INSTALLATION (cont)

Operating Safety

Due to potential for electrical shock within the Test Set, the Case Assembly must be closed when the Test Set is connected to an external power source.

Battery replacement, fuse replacement and internal adjustments must only be performed by qualified service technicians.

AC POWER REQUIREMENTS

The DC Power Supply, supplied with the IFR 6000, operates over a voltage range of 100 to 250 VAC at 47 to 63 Hz.

The battery charger operates whenever DC power (11 to 32 Vdc) is applied to the Test Set with the supplied DC Power Supply or a suitable DC power source. When charging, the battery reaches an 100% charge in approximately four hours. The Battery Charging temperature range is 5° to 40°C, controlled by an internal battery charger.

BATTERY RECHARGING

STEP	PROCEDURE
------	-----------

1. Connect AC Line Cable to either:
 - AC PWR Connector on the DC Power Supply and an appropriate AC power source
 - Suitable DC power source
2. Connect the DC Power Supply to the DC POWER Connector on the IFR 6000.
3. Verify the CHARGE Indicator illuminates yellow.
4. Allow four hours for battery charge or until the CHARGE Indicator illuminates green.

NOTE: If the CHARGE Indicator flashes yellow and/or the battery fails to accept a charge and the IFR 6000 does not operate on battery power, the battery, serviceable only by a qualified technician, requires replacement. Refer to Battery/Voltage Instructions.

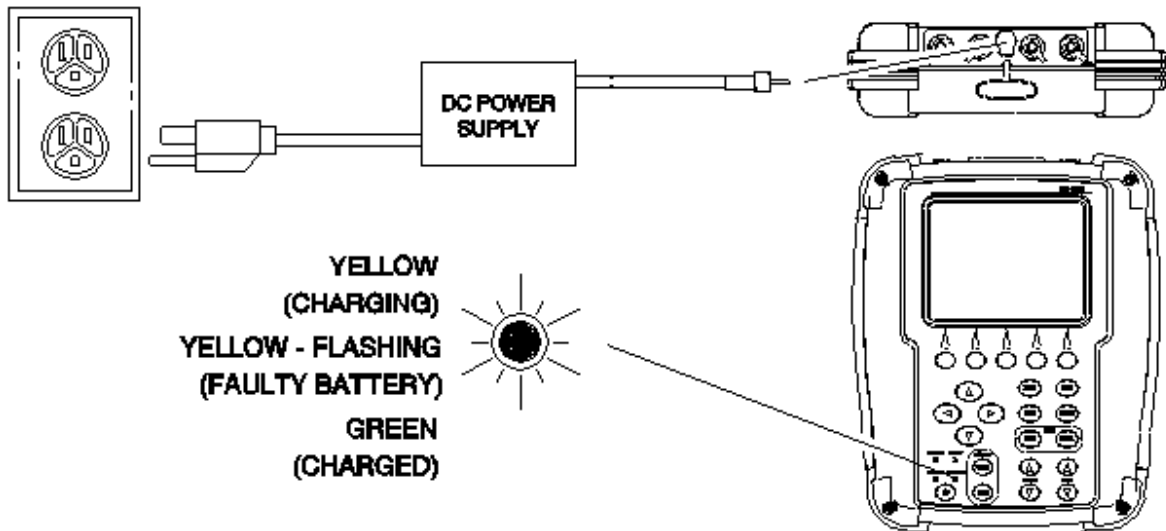

INSTALLATION (cont)

EXTERNAL CLEANING

The following procedure contains routine instructions for cleaning the outside of the Test Set.

CAUTION: DISCONNECT POWER FROM TEST SET TO AVOID POSSIBLE DAMAGE TO ELECTRONIC CIRCUITS.

STEP	PROCEDURE
------	-----------

1. Clean front panel buttons and display face with soft lint-free cloth. If dirt is difficult to remove, dampen cloth with water and a mild liquid detergent.
2. Remove grease, fungus and ground-in dirt from surfaces with soft lint-free cloth dampened (not soaked) with isopropyl alcohol.
3. Remove dust and dirt from connectors with soft-bristled brush.
4. Cover connectors, not in use, with suitable dust cover to prevent tarnishing of connector contacts.
5. Clean cables with soft lint-free cloth.
6. Paint exposed metal surface to avoid corrosion.

CONTROLS, CONNECTORS AND INDICATORS

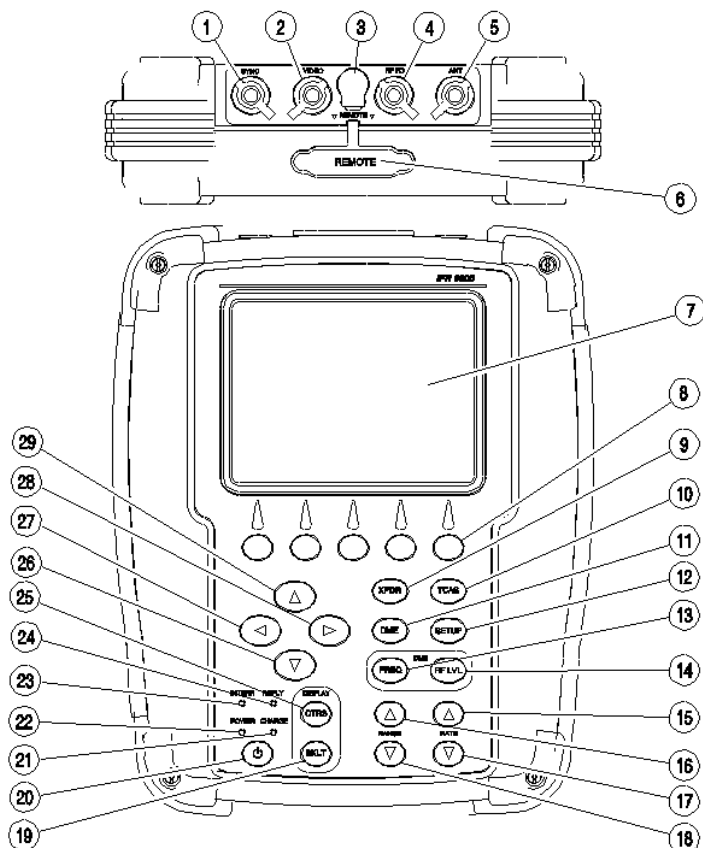

1. Test Set GPS Connector
2. VIDEO Connector
3. DC POWER Connector
4. RF I/O Connector
5. Test Set ANT Connector
6. REMOTE Connector
7. Display
8. Multi-Function Soft Keys
9. XPDR Mode Select Key
10. TCAS Mode Select Key
11. DME Mode Select Key
12. SETUP Select Key
13. FREQ Select Key
14. RF LVL Key
15. RATE INCREMENT Key
16. RANGE INCREMENT Key
17. RATE DECREMENT Key
18. RANGE DECREMENT Key
19. BACKLIGHT Key
20. POWER Key
21. CHARGE Indicator
22. POWER Indicator
23. INTERR Indicator
24. REPLY Indicator
25. CONTRAST Key
26. DECREMENT/SELECT Data Key
27. SELECT DATA UNIT MSB Key
28. SELECT DATA UNIT LSB Key
29. INCREMENT/SELECT Data Key
30. GPS Connector
31. ANT Connector
32. AUX OUT Connector 1
33. AUX OUT Connector 2
34. AUX OUT Connector 3
35. AUX OUT Connector 4
36. USB HOST Connector
37. USB DEVICE Connector
38. Altitude Encoder Connector
39. AUX IN Connector
40. RS-232 Connector
41. REMOTE Connector

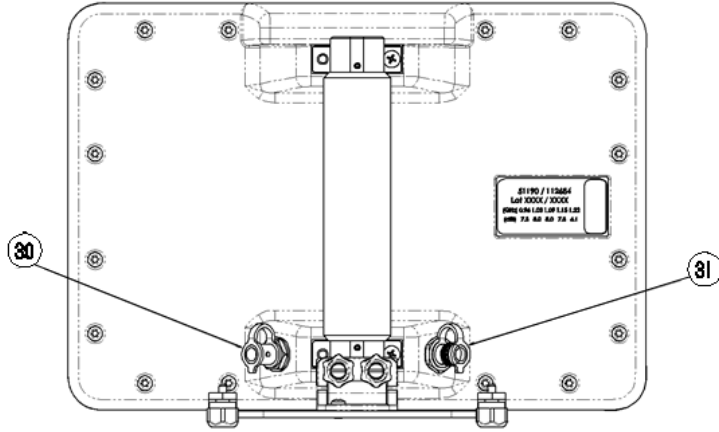

Directional Antenna

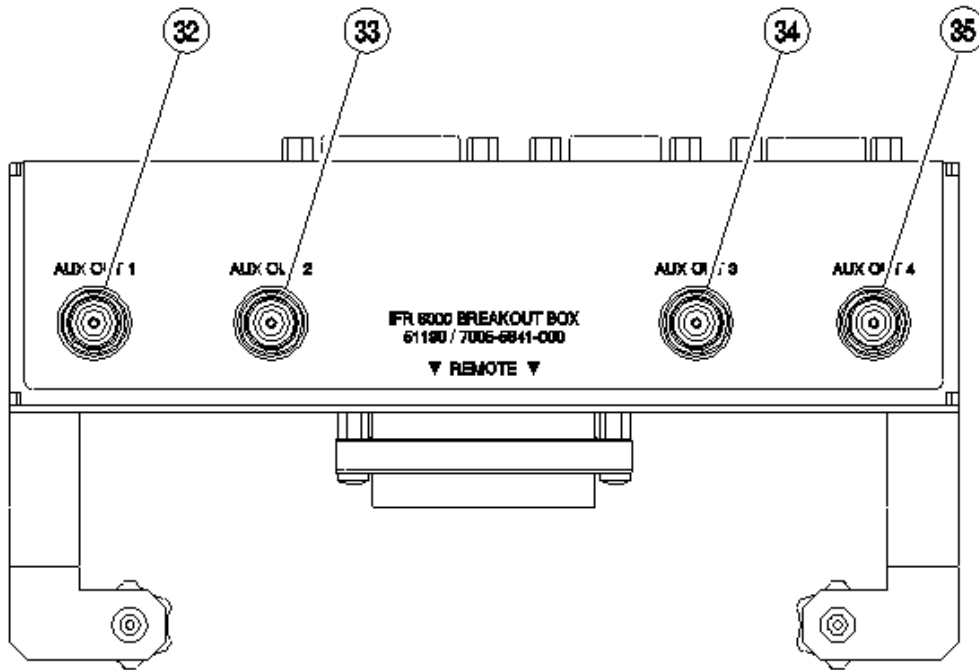

Breakout Box - Front View

CONTROLS, CONNECTORS AND INDICATORS (cont)

ITEM	DESCRIPTION
1.	Test Set GPS Connector If UAT Option is available, the BNC type connector provides connection to the GPS antenna.
2.	VIDEO Connector BNC type connector provides interrogation and reply pulses.
3.	DC POWER Connector Circular Type Connector (2.5 mm center, 5.5 mm outer diameter, center positive) used for battery charging or operation of Test Set.
4.	RF I/O Connector TNC Type connector used for direct connection to UUT antenna connector.
5.	ANT Connector TNC Type Connector used for connection to the IFR 6000 directional antenna for over the air testing.
6.	REMOTE Connector Type HD DB44 Connector used for remote operation and software upgrades. Contains RS-232, USB Host and USB Peripheral connections (altitude encoder inputs and SYNC outputs).
7.	Display (LCD) 38 characters by 16 lines for main screen display with Soft Key boxes at the bottom of the screen.
8.	Multi-Function Soft Keys Five Application dependent keys provide test specific information and movement between test screens. The legends are displayed in boxes at the bottom of the Display.
9.	XPDR MODE Select Key Selects Transponder Auto Test Screen.
10.	TCAS MODE Select Key Selects TCAS Auto Test Screen.
11.	DME MODE Select Key Selects DME Test Screen.
12.	SETUP Key Displays the SETUP Menu.
13.	FREQ Select Key Selects DME Frequency as VOR Paired, TACAN Channel or MHz.
14.	RF LVL Key DME mode function only. Selects DME range reply and squitter RF level.
15.	RATE INCREMENT Key Increments DME or TCAS range rate.

CONTROLS, CONNECTORS AND INDICATORS (cont)

ITEM	DESCRIPTION
16.	RANGE INCREMENT Key Increments DME or TCAS range.
17.	RATE DECREMENT Key Decrements DME or TCAS range rate.
18.	RANGE DECREMENT Key Decrements DME or TCAS range.
19.	BACKLIGHT Key Displays/exits the Backlight Adjust Field.
20.	POWER Key Powers the IFR 6000 ON and OFF.
21.	CHARGE Indicator Illuminated when external DC power is applied for Bench Operation or Battery charging.
22.	POWER Indicator Illuminated when the IFR 6000 is operational.
23.	INTERR Indicator Illuminated when Test Set is generating an interrogation signal (XPDR Mode) or receives an Interrogation (TCAS Mode) signal.
24.	REPLY Indicator Illuminated when the Test Set receives a valid reply signal (XPDR Mode) or generates a reply (TCAS Mode) signal.
25.	CONTRAST Key Displays/exits the Contrast Adjust Field.
26.	DECREMENT SELECT Data Key Decrements data in slewable fields, such as RF LVL. This Key also selects data in fields that have fixed functions, such as ECHO and SQUITTER.
27.	SELECT DATA UNIT MSB Key Moves the slew cursor toward the MSB (Most Significant Bit) of the data field.
28.	SELECT DATA UNIT LSB Key Moves the slew cursor toward the LSB (Least Significant Bit) of the data field.
29.	INCREMENT/SELECT Data Key Increments data in slewable fields, such as RF LVL. This Key also selects data in fields that have fixed functions, such as ECHO and SQUITTER.
30.	GPS Connector BNC Type Connector used for connection to the IFR 6000 for over the air testing.
31.	ANT Connector TNC Type Connector used for connection to the IFR 6000 for over the air testing.

CONTROLS, CONNECTORS AND INDICATORS (cont)

ITEM	DESCRIPTION
32.	AUX OUT Connector 1 ATCRBS interrogation trigger used for calibration.
33.	AUX OUT Connector 2 ATCRBS interrogation trigger used for calibration.
34.	AUX OUT Connector 3 BNC type connector serves as the SYNC connector and provides synchronization pulses for each test set transmission, e.g., interrogation, reply, squitter.
35.	AUX OUT Connector 4 Not used
36.	USB HOST Connector USB Flash Drive interface for software update.
37.	USB DEVICE Connector Remote Control Interface.
38.	ALTITUDE ENCODER Connector Interface for external encoding altimeter.
39.	AUX IN Connector Not used.
40.	RS-232 Connector Used for remote control interface, software update and test data dump.
41.	REMOTE Connector Used to interface with the IFR 6000.

AUXILIARY EQUIPMENT

DIRECTIONAL ANTENNA

The Directional Antenna is used two ways: on the Test Set or Tripod Mounted.



Mount Directional Antenna on friction hinge and connect Directional Antenna ANT Connector to Test Set ANT Connector via 12 in coaxial cable (PN: 62401). If UAT Option is available, connect the short RF coaxial cable (PN: 112831) between the Antenna GPS Connector and the Test Set GPS Connector.

Connect Directional Antenna ANT Connector to the Test Set ANT Connector via 72 in coaxial cable (PN: 112837). If UAT Option is available, connect the 72 in RF coaxial cable (PN: 112830) between the Antenna GPS Connector and the Test Set GPS Connector. The Directional Antenna can be held by hand or mounted on the tripod; point the Directional Antenna at the UUT antenna.

Distance for testing top UUT antenna should be sufficient so UUT antenna is visible. Distance for testing bottom UUT antenna should be close enough so that top UUT antenna is not visible. Supplied Antenna Shield should be mounted on bottom UUT antenna to avoid unwanted replies.

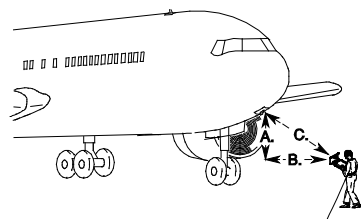
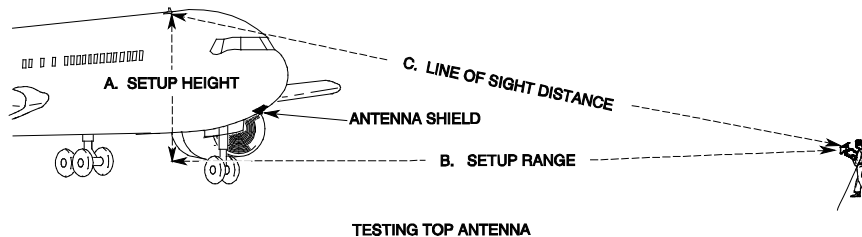

TESTING BOTTOM ANTENNA

WHEN DESELECTING, TERMINATING OR SHIELDING TOP ANTENNA IS NOT POSSIBLE OR PRACTICAL, USE SETUP POSITION THAT HAS AIRCRAFT BLOCKING LINE OF SIGHT TO TOP ANTENNA.

05818A

AUXILIARY EQUIPMENT (cont)

BREAKOUT BOX

The Breakout Box accessory provides access to individual user interfaces via standard connectors). The Test Set Remote Connector provides the main user signal interface for the Breakout Box.

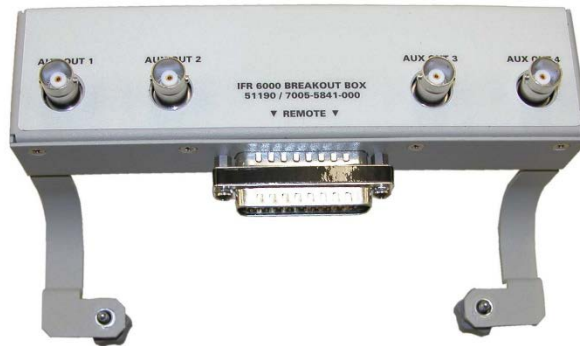

The Breakout Box attaches to the Test Set via a remote connector located on the top of the Test and thumb screws on the back.

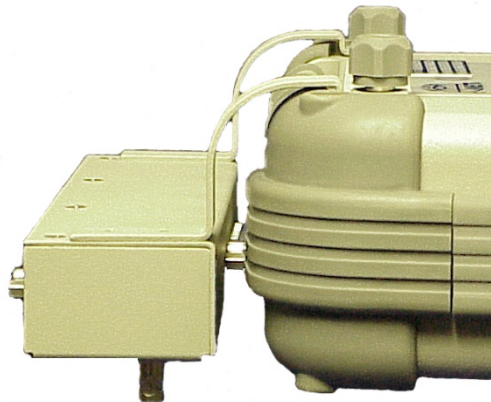

SCREEN HIERARCHY

The XPDR AUTO TEST Screen always appears on Power-Up.

XPDR-AUTO TEST	PASS	BAT 2.5 Hr
CONFIG:GENERIC MODE S		LEVEL=4
ANTENNA: BOTTOM		
REPLIES =A,C,S	FREQ =1090.12 MHZ	
TOP ERP =57.1 dBm	MTL =-74.0 dBm	
BOT ERP =56.0 dBm	MTL =-73.1 dBm	
A CODE =1234	C ALT =35000 ft	
S CODE =1234	S ALT =35000 ft	
TAIL =N12345	DF17 DETECTED=NO	
FLT ID =AA-50	AA=AC3421(53032041)	
FS=5-NO ALERT	SPI IN AIR	
VS=IN AIR	COUNTRY=United States	
RUN TEST	TEST LIST	SELECT ANT

The SETUP Menu allows the operator to set various parameters used in testing, configuration and memory storage. Press the SETUP Key to display the XPDR Setup Screen, press again for the DME Setup Screen, again for General Setup Screen.

SETUP-XPDR	BAT 2.5 Hr
ANTENNA: BOTTOM RF PORT:ANTENNA	
ANT RANGE	ANT HEIGHT
TOP: 50.0 m	10.0 m
BOTTOM: 50.0 m	0.0 m
ANT CABLE LEN: 6 FT	ANT GAIN (dBi)
ANT CABLE LOSS: 1.8 dB	0.96 GHz: 7.5
COUPLER LOSS: 0.8 dB	1.03 GHz: 7.1
UUT ADDRESS:AUTO	1.09 GHz: 6.1
MANUAL AA:123456	PWR LIM: FAR 43
DIV TEST:ON	RAD47:OFF
CHECK CAP: YES	
ADSB SETUP	PREV PARAM
NEXT PARAM	DIAG
TEST DATA	

SETUP-DME	BAT 2.5 Hr
RF PORT : DIRECT CONNECT	
ANT RANGE : 10.5 m	
IDENT TONE : IFR	ANT GAIN (dBi)
DIR CABLE LOSS: 1.2 dB	1.03 GHz :7.1
ANT CABLE:25 FT	1.09 GHz :6.1
ANT CABLE LOSS: 4.0 dB	1.15 GHz :5.0
MAX RANGE:200.00 nm	1.22 GHz :2.8
PREV PARAM	NEXT PARAM
DIAG	

SETUP - GENERAL	BAT 2.5 Hr
PWR DOWN : 10 mins	
ERP UNITS : dBm	UNITS : METERS
REMOTE OPERATION : RS232	
PREV PARAM	NEXT PARAM
H/W TOOLS	INFO

SCREEN HIERARCHY (cont)

The XPDR AUTO TEST Screen is the opening screen. The screens are changed by pressing the XPDR Mode Key or an application specific Soft Key.

Screen Organization

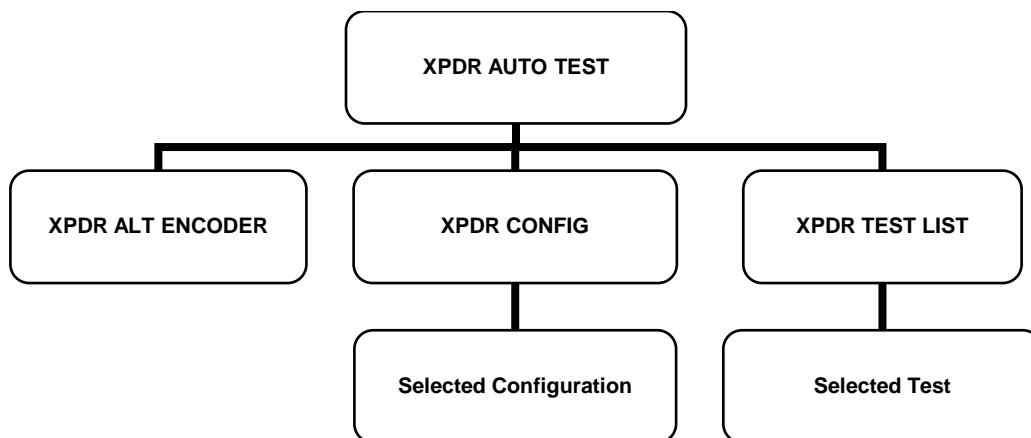

The XPDR Auto Test Screen is the primary test screen. When a Mode S configuration is selected the test list is displayed over two screens and ATCRBS configurations display the test list on one screen.

XPDR-AUTO TEST	PASS	BAT 2.5 Hr
CONFIG:GENERIC MODE S		LEVEL=4
ANTENNA: BOTTOM		
REPLIES =A,C,S	FREQ =1090.12 MHZ	
TOP ERP =57.1 dBm	MTL =-74.0 dBm	
BOT ERP =56.0 dBm	MTL =-73.1 dBm	
A CODE =1234	C ALT =35000 ft	
S CODE =1234	S ALT =35000 ft	
TAIL =N12345	DF17 DETECTED=NO	
FLT ID =AA-50	AA=AC3421(53032041)	
FS=5-NO ALERT	SPI IN AIR	
VS=IN AIR	COUNTRY=United States	
RUN TEST	TEST LIST	CONFIG SELECT ANT

SCREEN HIERARCHY (cont)

Press the Test List Soft Key to access 17 additional XPDR Test Screens.

A/C Decoder/SLS Test Screen

XPDR-A/C DECDR/SLS			PASS	BAT 2.5 Hr
DECODER INNER LOW	A=PASS	C=PASS		
DECODER INNER HIGH	A=PASS	C=PASS		
DECODER OUTER LOW	A=PASS	C=PASS		
DECODER OUTER HIGH	A=PASS	C=PASS		
SLS 0 dB	A=PASS	C=PASS		
SLS -9 dB	A=PASS	C=PASS		
A CODE = 2620 IDENT				
A4 A2 A1 B4 B2 B1 C4 C2 C1 D4 D2				
C ALT = 100000 ft				
A4 A2 A1 B4 B2 B1 C4 C2 C1 D4 D2				
RUN TEST	PREV TEST	NEXT TEST	RETURN	

S All Call Test Screen

XPDR-S ALL-CALL			PASS	BAT 2.5 Hr
ITM REPLY				
DELAY	A=128.08 us	C=128.07 us		
JITTER	A=0.510 us	C=0.510 us		
ADDRESS	A=2AC421	C=2AC421		
RATIO	A=100%	C=100%		
-81dBm	A=0%	C=0%		
MODE S ALL-CALL= PASS				
ADDRESS = 2AC421				
TAIL= N12345				
COUNTRY= United States				
RUN TEST	PREV TEST	NEXT TEST	RETURN	

A/C Spacing Width Test Screen

XPDR-A/C SPAC/WDTH			FAIL	BAT 2.5 Hr
F1WIDTH	▶ A= 0.300 us	C= 0.450 us		
F2WIDTH	A= 0.400 us	▶ C= 0.600 us		
F1-F2	A=20.300 us	C=20.300 us		
REPLY DELAY	A=3.05 us	▶ C=3.55 us		
REPLY JITTER	A=0.250 us	C=0.000 us		
REPLY RATIO	A=100%	C=100%		
-81dBm REPLY RATIO	A=0%	C=0%		
ATCRBS ALL-CALL A=PASS C=PASS				
PULSE AMP VAR A=0.0 dB C=0.0 dB				
RUN TEST	PREV TEST	NEXT TEST	RETURN	

S Reply Timing Test Screen

XPDR-S RPLY TIMING			FAIL	BAT 2.5 Hr
▶ REPLY DELAY =148.05 us				
▶ REPLY JITTER=0.950 us				
PULSE WIDTH=PASS				
▶ PULSE SPACING =FAIL				
RUN TEST	PREV TEST	NEXT TEST	RETURN	

Power and Frequency Test Screen

XPDR - POWER/FREQ				PASS	BAT 2.5 Hr
TX FREQ = 1090.12 MHz ANTENNA:TOP					
MEASURED VIA	TOP DIRECT	BOTTOM ANTENNA	INSTANT DIRECT		
MTL (DBm)					
ATCRBS	-73.2	-73.1	-73.2		
A-C DIFF	0.2	-0.1	0.0		
ALL CALL	-73.0	-73.2	-73.2		
MODE S	-73.2	-72.9	-73.2		
ERP (dBm)	57.1	57.0	57.0		
RUN TEST	PREV TEST	NEXT TEST	RETURN		

S Reply Test Screen

XPDR-S REPLY			PASS	BAT 2.5 Hr
PULSE AMP VAR SHRT=0.1 dB LNG=0.1 dB				
SLS ON=NO REPLY OFF=REPLY				
SQTR DF11 PERIOD=1.00s				
DF17 DETECTED=YES				
REPLY RATIO =100%				
REPLY RATIO 81dBm =0%				
INVALID AA =PASS				
DIVERSITY ISOLATION=GREATER THAN 25dB				
RUN TEST	PREV TEST	NEXT TEST	RETURN	

SCREEN HIERARCHY (cont)

UF0 Test Screen

XPDR - UFO	PASS	BAT 2.5 Hr	
DF = 0 VS = 0 - IN AIR CC = 0 - NOT SUPPORTED SL = 0 - NO TCAS SENS LEVEL REPORTED RI = 12 - AIRSPEED 301 TO 600 KNOTS			
AC = 03A0(01640) 10700 FT MODE C ALT COMPARE = PASS AA = AC3421(53032041) DF11 ADDRESS COMPARE = PASS			
RUN TEST	PREV TEST	NEXT TEST	RETURN

UF11 Test Screen

XPDR-UF11	PASS	BAT 2.5 Hr	
DF=11 CA=0-LEVEL 2 CA MODE PI =02F08D AA=AC3421(53032041)			
II MATCH=PASS SI LOCKOUT TIMER=16S SI MATCH=PASS			
RUN TEST	PREV TEST	NEXT TEST	RETURN

UF4 Test Screen

XPDR - UF4	PASS	BAT 2.5 Hr	
DF = 4 FS = 3 - ALERT NO SPI ON GROUND DR = 0 - NO DOWNLINK REQUEST UM = 0 - (IDS = 0) (IIS = 0)			
AC = 03A0(01640) 10700 FT MODE C ALT COMPARE = PASS AA = AC3421(53032041) DF11 ADDRESS COMPARE = PASS			
RUN TEST	PREV TEST	NEXT TEST	RETURN

UF16 Test Screen

XPDR-UF16	PASS	BAT 2.5 Hr	
DF=16 VS=0 - IN AIR SL=0 RI=0-NO ON - BOARD TCAS MV=30010000000000			
AC=03A0(01640) 10700 ft MODE C ALT COMPARE=PASS AA=AC3421(53032041) DF11 ADDRESS COMPARE=PASS			
RUN TEST	PREV TEST	NEXT TEST	RETURN

UF5 Test Screen

XPDR-UF5	PASS	BAT 2.5 Hr	
DF=5 FS=0-NO ALERT NO SPI IN AIR DR=0-NO DOWNLINK REQUEST UM=0 - (IDS = 0) (IIS = 0)			
ID=020A(01012) OCTAL ID 2600 MODE A ID COMPARE=PASS AA=AC3421(53032041) DF11 ADDRESS COMPARE=PASS			
RUN TEST	PREV TEST	NEXT TEST	RETURN

UF20 Test Screen

XPDR-UF20	PASS	BAT 2.5 Hr	
DF=20 FS=3-ALERT NO SPI ON GROUND DR=0-NO DOWNLINK REQUEST UM=0 (IDS=0) (IIS = 0) MB=30010000000000			
AC=03A0(01640) 10700 ft MODE C ALT COMPARE=PASS AA=AC3421(53032041) DF11 ADDRESS COMPARE=PASS			
RUN TEST	PREV TEST	NEXT TEST	RETURN

SCREEN HIERARCHY (cont)

UF21 Test Screen

XPDR-UF21		PASS	BAT 2.5 Hr
DF=21 FS=3-ALERT NO SPI ON GROUND DR=0-NO DOWNLINK REQUEST UM=0 (IDS=0) (IIS = 0) MB=30010000000000			
ID=03A0(01640) OCTAL ID 6140 MODE A ID COMPARE=PASS AA=AC3421(53032041) DF11 ADDRESS COMPARE=PASS			
RUN TEST	PREV TEST	NEXT TEST	RETURN

Elementary Surveillance 2 Test Screen

XPDR-ELEMENT SURV2		PASS	BAT 2.5 Hr
BDS=1,7 :0,5 :0,6 :0,7 :0,8 :0,9 :0,A :2,0 :2,1 :4,0 :4,1 :4,2 :4,3 :4,4 :4,5 :4,8 :5,0 :5,1 :5,2 :5,3 :5,4 :5,5 :5,6 :5,F :6,0 BDS 1,8=00000000000000 BDS 1,9=00000000000000 BDS 1,A=00000000000000 BDS 1,B=00000000000000 BDS 1,C=00000000000000 BDS=2,0 FLIGHT ID=UA661 BDS=3,0 ARA=11101010000000 RAC=1010 RAT=0			
RUN TEST	PREV TEST	NEXT TEST	RETURN

UF24 Test Screen

XPDR-UF24		PASS	BAT 2.5 Hr
RESERVATION UF 4 DF=20 IIS=15 IDS=2 AA=AC3421			
SEGMENTS UF24 DF=24 KE=1 ND=0 TAS=FFFF AA=AC3421			
CLOSEOUT UF 4 DF=20 IIS=15 IDS=2 AA=AC3421			
RUN TEST	PREV TEST	NEXT TEST	RETURN

Enhanced Surveillance Test Screen

XPDR-ENHANCED SURV		PASS	BAT 2.5 Hr
BDS4,0 MCP/FCU SEL ALT =65520 ft BARO PRES SET = BDS5,0 ROLL ANGLE = 40.1 deg TRUE TRACK ANGLE= 90.3 deg GROUND SPEED = 512 kts TRACK ANGLE RATE= 4.00 deg/s TRUE AIR SPEED = 512 kts BDS6,0 MAGNETIC HEADING= 180.3 deg IND AIR SPEED = 512 kts MACH NO = 0.300 INERT VERT VEL =-1400 ft/min BARO ALT RATE =-1400 ft/min			
RUN TEST	PREV TEST	NEXT TEST	RETURN

Elementary Surveillance 1 Test Screen

XPDR - ELEMENT SURV1 PASS BAT 2.5 Hr			
BDS=1,0	SUBNETWORK VER	=1	
	ENH PROT IND	=LVL 2-4	
	SPEC SERV CAP	=YES	
	UELM CAPABILITY	=16/1 s	
	DELM CAPABILITY	=16/500 ms	
	AIRCRAFT ID CAP	=YES	
	SURV IDENT CAP	=YES	
	COMM USE GICB REP	=1	
	DTE	=YES	
	CONT FLAG	=YES	
	SQUITTER CAP	=YES	
RUN TEST	PREV TEST	NEXT TEST	RETURN

SELF TEST

The IFR 6000 is equipped with a Self Test for quick performance evaluation. An abbreviated Self Test is run at Power-Up. The full Self Test is initiated manually.

POWER-UP

Press the POWER Key on the IFR 6000 to display the Startup Screen. After several seconds, the XPDR AUTO TEST Screen is displayed.

XPDR-AUTO TEST	PASS	BAT 2.5 Hr
CONFIG:GENERIC MODE S		LEVEL=4
ANTENNA: BOTTOM		
REPLIES =A,C,S	FREQ =1090.12 MHZ	
TOP ERP =57.1 dBm	MTL =-74.0 dBm	
BOT ERP =56.0 dBm	MTL =-73.1 dBm	
A CODE =1234	C ALT =35000 ft	
S CODE =1234	S ALT =35000 ft	
TAIL =N12345	DF17 DETECTED=NO	
FLT ID =AA-50	AA=AC3421(53032041)	
FS=5-NO ALERT	SPI IN AIR	
VS=IN AIR	COUNTRY=United States	
RUN TEST	TEST LIST	CONFIG
		SELECT ANT

SELF TEST (cont)

RUN SELF TEST

Press SETUP Key to display the Setup Menu.

SETUP - GENERAL		BAT 2.5 Hr	
PWR DOWN : 10 mins			
ERP UNITS : dBm		UNITS : METERS	
REMOTE OPERATION : RS232			
PREV PARAM	NEXT PARAM	HW TOOLS	INFO

Press HW TOOLS Soft Key to display the Hardware Tools Screen.

SETUP - HARDWARE TOOLS		BAT 2.5 Hr	
S/N 103009999			
MULTI-FUNCTION BOARD REV 0			
RF BOARD REV 1.0			
CPU BOARD REV 0			
AMBIENT TEMPERATURE = 78F 26C			
RF BLOCK TEMPERATURE = 78F 26C			
RS232	SELF TEST	CAL	RETURN

SELF TEST (cont)

RUN SELF TEST (cont)

Press SELF TEST Soft Key to display the Self Test Screen.

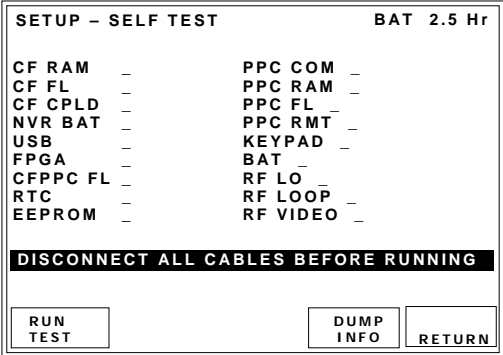

Press RUN TEST Soft Key to initiate the Self Test.

Verify that all the modules/assemblies pass the Self Test. If the Self Test indicates a failure, contact VIAVI for additional information.

THIS PAGE INTENTIONALLY LEFT BLANK.

**FOR QUALIFIED SERVICE
PERSONNEL ONLY**

**BATTERY/VOLTAGE
INSTRUCTIONS**

THIS PAGE INTENTIONALLY LEFT BLANK.

SAFETY FIRST: TO ALL SERVICE PERSONNEL

REFER ALL SERVICING OF UNIT TO QUALIFIED TECHNICAL PERSONNEL.

WARNING: USING THIS EQUIPMENT IN A MANNER NOT SPECIFIED BY THE ACCOMPANYING DOCUMENTATION MAY IMPAIR THE SAFETY PROTECTION PROVIDED BY THE EQUIPMENT.

CASE, COVER OR PANEL REMOVAL

Opening the Case Assembly exposes the technician to electrical hazards that can result in electrical shock or equipment damage.

SAFETY IDENTIFICATION IN TECHNICAL MANUAL

This manual uses the following terms to draw attention to possible safety hazards, that may exist when operating or servicing this equipment.

CAUTION: THIS TERM IDENTIFIES CONDITIONS OR ACTIVITIES THAT, IF IGNORED, CAN RESULT IN EQUIPMENT OR PROPERTY DAMAGE (E.G., FIRE).

WARNING: THIS TERM IDENTIFIES CONDITIONS OR ACTIVITIES THAT, IF IGNORED, CAN RESULT IN PERSONAL INJURY OR DEATH.

SAFETY SYMBOLS IN MANUALS AND ON UNITS



CAUTION: Refer to accompanying documents. (This symbol refers to specific CAUTIONS represented on the unit and clarified in the text.)



AC OR DC TERMINAL: Terminal that may supply or be supplied with AC or DC voltage.



DC TERMINAL: Terminal that may supply or be supplied with DC voltage.



AC TERMINAL: Terminal that may supply or be supplied with AC or alternating voltage.

EQUIPMENT GROUNDING PRECAUTION

Improper grounding of equipment can result in electrical shock.

USE OF PROBES

Check specifications for the maximum voltage, current and power ratings of any connector on the Test Set before connecting it with a probe from a terminal device. Be sure the terminal device performs within these specifications before using it for measurement, to prevent electrical shock or damage to the equipment.

POWER CORDS

Power cords must not be frayed, broken nor expose bare wiring when operating this equipment.

USE RECOMMENDED FUSES ONLY

Use only fuses specifically recommended for the equipment at the specified current and voltage ratings.

SAFETY FIRST: TO ALL SERVICE PERSONNEL (cont)

WARNING: THE IFR 6000 USES A LITHIUM ION BATTERY PACK. THE FOLLOWING WARNINGS CONCERNING LITHIUM ION BATTERIES MUST BE HEEDED:

- DO NOT RECHARGE OUTSIDE THE IFR 6000.
- DO NOT CRUSH, INCINERATE OR DISPOSE OF IN NORMAL WASTE.
- DO NOT SHORT CIRCUIT OR FORCE DISCHARGE AS THIS MIGHT CAUSE THE BATTERY TO VENT, OVERHEAT OR EXPLODE.

CAUTION: INTEGRATED CIRCUITS AND SOLID STATE DEVICES SUCH AS MOS FETS, ESPECIALLY CMOS TYPES, ARE SUSCEPTIBLE TO DAMAGE BY ELECTROSTATIC DISCHARGES RECEIVED FROM IMPROPER HANDLING, THE USE OF UNGROUNDED TOOLS AND IMPROPER STORAGE AND PACKAGING. ANY MAINTENANCE TO THIS UNIT MUST BE PERFORMED WITH THE FOLLOWING PRECAUTIONS:

- BEFORE USE IN A CIRCUIT, KEEP ALL LEADS SHORTED TOGETHER EITHER BY THE USE OF VENDOR-SUPPLIED SHORTING SPRINGS OR BY INSERTING LEADS INTO A CONDUCTIVE MATERIAL.
- WHEN REMOVING DEVICES FROM THEIR CONTAINERS, GROUND THE HAND BEING USED WITH A CONDUCTIVE WRISTBAND.
- TIPS OF SOLDERING IRONS AND/OR ANY TOOLS USED MUST BE GROUNDED.
- DEVICES MUST NEVER BE INSERTED INTO NOR REMOVED FROM CIRCUITS WITH POWER ON.
- PC BOARDS, WHEN TAKEN OUT OF THE SET, MUST BE LAID ON A GROUNDED CONDUCTIVE MAT OR STORED IN A CONDUCTIVE STORAGE BAG. REMOVE ANY BUILT-IN POWER SOURCE, SUCH AS A BATTERY, BEFORE LAYING PC BOARDS ON A CONDUCTIVE MAT OR STORING IN A CONDUCTIVE BAG.
- PC BOARDS, IF BEING SHIPPED TO THE FACTORY FOR REPAIR, MUST BE PACKAGED IN A CONDUCTIVE BAG AND PLACED IN A WELL-CUSHIONED SHIPPING CONTAINER.



CAUTION: SIGNAL GENERATORS CAN BE A SOURCE OF ELECTROMAGNETIC INTERFERENCE (EMI) TO COMMUNICATION RECEIVERS. SOME TRANSMITTED SIGNALS CAN CAUSE DISRUPTION AND INTERFERENCE TO COMMUNICATION SERVICES OUT TO A DISTANCE OF SEVERAL MILES. USERS OF THIS EQUIPMENT SHOULD SCRUTINIZE ANY OPERATION THAT RESULTS IN RADIATION OF A SIGNAL (DIRECTLY OR INDIRECTLY) AND ENSURE COMPLIANCE WITH INSTRUCTIONS IN FAA CIRCULAR AC 170-6C, DATED FEBRUARY 19, 1981.

FOR QUALIFIED SERVICE PERSONNEL ONLY

FUSE REPLACEMENT

STEP	PROCEDURE
------	-----------

1. Verify the IFR 6000 is OFF and not connected to AC power.
2. Fully loosen two captive screws in the two lower bumpers and remove the bumpers.
3. Fully loosen five captive screws and lift the Battery Cover from the Case Assembly.
4. Replace fuse:

5 A, 32 Vdc, Type F
(Mini Blade Fuse)
(VIAVI PN: 56080)

CAUTION: FOR CONTINUOUS PROTECTION AGAINST FIRE, REPLACE ONLY WITH FUSES OF THE SPECIFIED VOLTAGE AND CURRENT RATINGS.

5. Install the Battery Cover on the Case Assembly and tighten the five captive screws (8 in/lbs.).
6. Install the two lower bumpers and tighten the two captive screws in each bumper (8 in/lbs.).

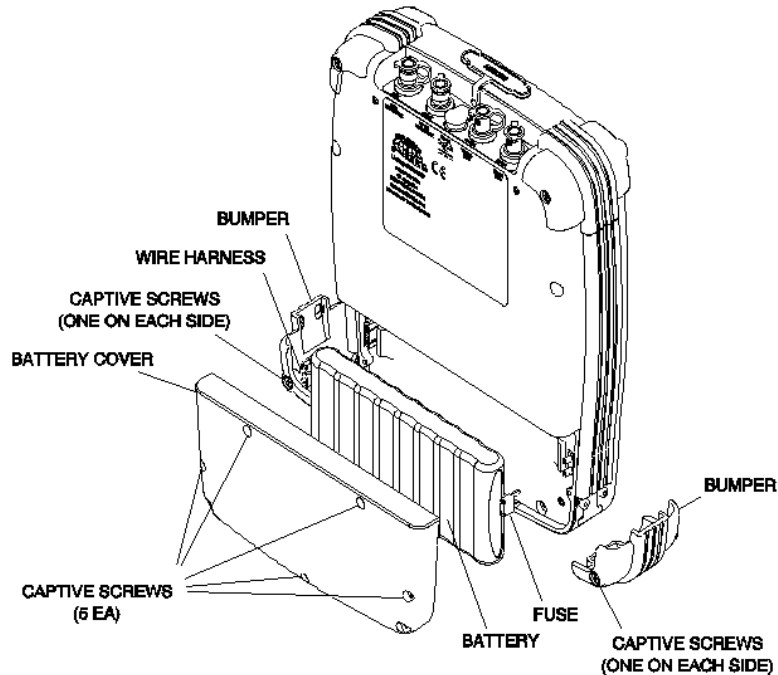

FOR QUALIFIED SERVICE PERSONNEL ONLY

BATTERY REPLACEMENT

STEP	PROCEDURE
------	-----------

1. Verify the IFR 6000 is OFF and not connected to AC power.
2. Fully loosen two captive screws in the two lower bumpers and remove the bumpers.
3. Fully loosen five captive screws and lift the Battery Cover from the Case Assembly.
4. Disconnect the wire harness connecting the battery to the Test Set and remove the battery.
5. Install new battery and reconnect the wire harness.
6. Install the Battery Cover on the Case Assembly and tighten the five captive screws (8 in/lbs.).
7. Install the two lower bumpers and tighten the two captive screws in each bumper (8 in/lbs.).

WARNING: DISPOSE OF OLD BATTERY ACCORDING TO LOCAL STANDARD SAFETY PROCEDURES.

CAUTION: REPLACE ONLY WITH THE BATTERY SPECIFIED BY VIAVI. DO NOT ATTEMPT TO INSTALL A NON-RECHARGEABLE BATTERY.

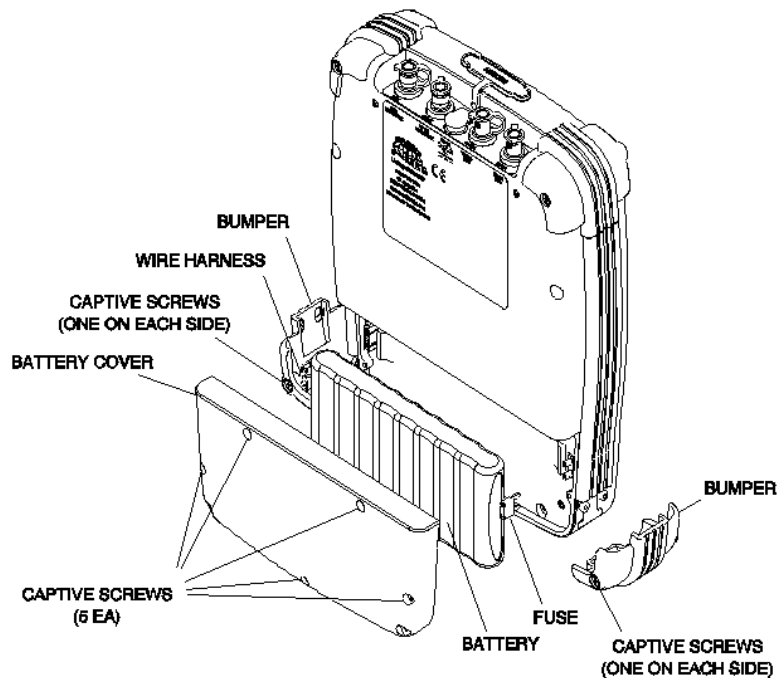



6096 Rev. E0



December 2019

VIAVI Solutions

North America: 1.844.GO VIAVI / 1.844.468.4284

Latin America +52 55 5543 6644

EMEA +49 7121 862273

APAC +1 512 201 6534

All Other Regions: [viavisolutions.com/contacts](https://www.viavisolutions.com/contacts)