

# Performing In-Service Loss Measurements in Passive Optical FTTX Networks

Passive optical networks (PONs) typically operate at the edge of the loss budget, and just one dB additional loss can disrupt service. It is important to know the actual loss of the individual fiber links to prove that the system is operating in the specified range. This application note describes a non-disruptive method for testing optical fibers in an active FTTX network to ensure best network performance and the best customer experience.

FTTX network systems are typically installed and maintained in three phases:

- Construction of the physical layer (such as optical cables, splices, splitters, and termination boxes)
- Service activation (connecting and turning-up optical line terminals (OLTs), optical network units (ONUs), and optical network terminals (ONTs))
- Maintenance and troubleshooting (such as identifying and locating fiber misalignments, bended fibers, dirty connectors, and defective ONUs)

The phases do not always occur sequentially. During construction, all homes are passed but not all will subscribe to a service and get activated immediately. Customers may subscribe several years later and get the service connected and activated then.

## Physical Layer Testing During Construction

During the construction phase, the fiber plant must be qualified. End-to-end loss testing with an optical power meter and an optical light source ensures that a fiber link complies with the loss budget. An OTDR test locates individual loss and fiber bending and provides return loss values for each connection, splice, and splitter.

## Service Activation with a Wavelength-Selective Power Meter (PON Power Meter)

For service activation, a PON power meter simultaneously measures the power of all upstream and downstream wavelengths on live G-PONs or next-generation XG-PONs and 10G-EPONs. This ensures reliable operation based on the transmission standards used between the terminals. A PON power meter accurately measures the signals level of the OLT and ONU/ONT but cannot test fiber-link loss.

## Service Activation with In-Service Loss Testers

Due to the presence of downstream signals from the OLT as well as upstream signals from already-activated ONUs/ONTs, it is not possible to perform a traditional loss test using a standard optical light source and a broadband power meter. An in-service optical power meter which can separate the test signal of an optical light source from OLT or ONU/ONT signals is mandatory to perform an in-service loss test. The light source must work at a test wavelength that is outside of the operating wavelengths at 1490/1310 nm for G-PON and 1578/1270 nm for XG-PON or 1550 nm for CATV. Therefore, the preferred wavelengths for an in-service loss test are 1625 nm or 1650 nm.

## Viavi Solutions™ SmartClass™ Fiber Solutions for In-Service Loss Testing

SmartClass Fiber instruments test in-service loss without the need for special power meters with mechanical optical filters. A Viavi in-service power meter comes with special signal-processing firmware that uses fast Fourier transformation (FFT) to separate a modulated 1625 nm test signal generated by a Viavi optical light source from the downstream/upstream signals transmitted by the OLT and the ONUs/ONTs.

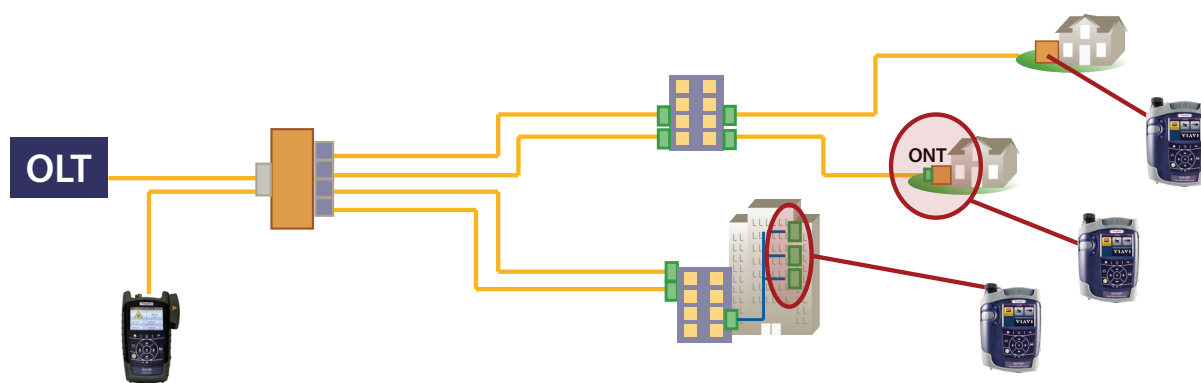

### Optical Light Source

- Connected 24/7 at test-point next to OLT
- Continuously emitting at 1625 nm with special

### Optical Power Meter

- FFT filter to block downstream signal
- Several loss tests at different locations can be

Figure 1. In-service loss testing

Via a 2:1 WDM splitter, the optical light source connects with an OLT into the feeder fiber of a PON. The optical light source generates a stabilized test signal at 1625 nm and runs continuously, 24/7. At test points in the PON, such as a splitter port or a termination box where new customers will be connected, the test signal is measured with Viavi optical power meters (OPMs). These meters provide accurate insertion-loss values between the OLT and the points of test. This technology enables simultaneous in-service loss testing at several locations in the network.

Using a downstream signal from the OLT instead of the stabilized signal from a Viavi light source would lead to inaccurate and non-reliable results—the OLT power level changes too much over time. The Viavi light source signal is very stable and accurate, allowing for manual remote entry of loss-test reference values into different OPMs without the need for local referencing with the light source.

## The Importance of Fiber Optic Connector Inspection and Cleaning Together with In-Service Loss Testing

To secure the lowest insertion loss values, it is mandatory to follow a standardized *Inspect Before You Connect* (IBYC) workflow. SmartClass Fiber instruments can connect with a P5000i microscope and come in patch-cord microscope versions for automated pass/fail fiber inspection analysis.

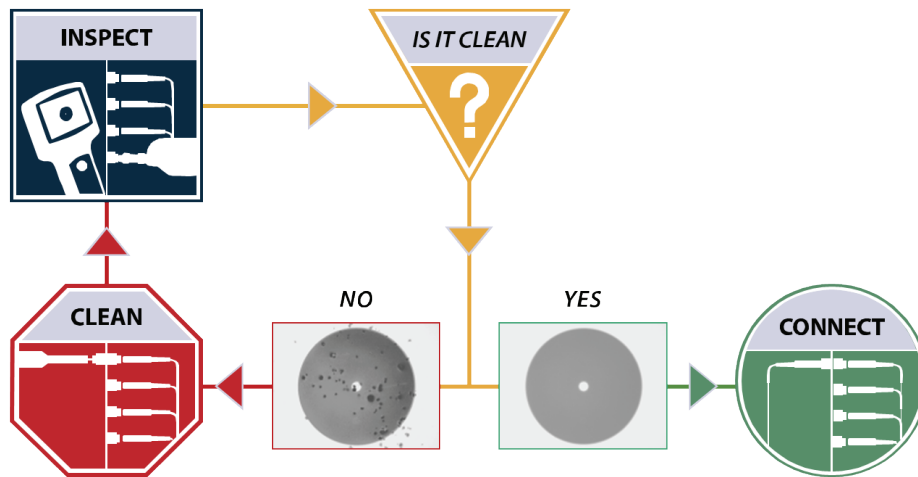

Figure 2. The Inspect Before You Connect workflow

## FAQs

### Which Type of Splitter is Recommended at the Test Point?

Use a WDM splitter at the test point. This guarantees the lowest possible insertion loss and is ready for future use with remote fiber test systems.

### Can I Use the Signal of the OLT to Perform a Loss Test?

No, the downstream signal of an OLT varies over time and is not stable enough as a long-term reference for an accurate loss test. For referencing with an OPM, the OLT needs to be disconnected from the PON which means the service will be disrupted. When replacing an OLT, the power level of the new OLT will be significantly different. Also, as soon as more than one downstream signal is present (1490 nm and 1550 nm), the test signal needs to be modulated to be filtered using FFT to avoid the extra effort of mechanical optical filtering.

### Is There Still a Need for In-Service OTDR Testing?

And in-service loss test provides a real-time, precise value of end-to-end loss and is the fastest way to get a pass/fail decision about a specific link. It is very easy to set up a test and perform it, and is the methodology for non-fiber experts in a mass FTTX rollout.

In-service OTDR provides detailed information about the location and quality of individual events in the fiber link (splices, splitters, connectors, and fiber length). There is no other practical way to locate an individual issue (bad splice, fiber bend, or dirty connector) in a running FTTX network than by using in-service OTDR.

The use of both in-service loss. Test and in-service OTDR is the best way to optimize and structure the economical use of different test tools and different engineers in a workflow.

### **How Do I Reference between the Optical Light Source and a Viavi OLP Instrument?**

The signal of a Viavi light source is very stable and accurate, enabling manual remote entry of loss test reference values into different OPMs without the need for local referencing with the light source which is located at the OLT side.

### **Can I Use Light Sources Other than the OLS-85, OLT-85, or ORL-85 for In-Service Loss Tests?**

No, only light sources in the SmartClass Fiber product family have special modulation that a SmartClass Fiber power meter with the optional in-service loss test option can detect.

## **Conclusion**

The primary benefits of in-service loss testing with Viavi SmartClass Fiber instruments are:

- Quick and economical in-service, end-to-end link qualification
- Efficient turn-up of new customers in an already-running network
- One light source at the OLT side running continuously simultaneously supports multiple field engineers with OPMs at the ONTs or splitters
- Enables using the OLT test point (1:2 splitter) for connecting a fiber monitoring system after service turn-up is completed



Contact Us **+1 844 GO VIAVI**  
(+1 844 468 4284)

To reach the Viavi office nearest you,  
visit [viavisolutions.com/contacts](http://viavisolutions.com/contacts).

© 2015 Viavi Solutions Inc.  
Product specifications and descriptions in this  
document are subject to change without notice.  
inservicelosspon-an-fop-nse-ae  
30175999 900 1014